

Slingmax® Rigging Solutions ■ Wire Rope Slings ■ Alloy Chain Slings ■ Web Slings ■ Roundslings ■ Metal Mesh Slings





Lifting People & Materials to New Heights



General Information & Warnings

All products fabricated by Bishop Lifting Products, Inc., are sold with the express understanding that the purchaser and user is thoroughly familiar with the safe use, proper care, and application of the product.

Responsibility for the safe use, proper care, and application of the product rests with the user.

Failure of the product can occur due to misapplication, abuse, overloading, or improper care, and maintenance.

There are numerous government and industry standards that cover products made by Bishop Lifting Products, Inc. This catalog makes no attempt to reference all of them. We do reference standards that are most current like ASME B30.9 "Slings."

Ratings shown in Bishop Lifting Products, Inc. literature are only applicable to new or in "as new" condition products.

Rated capacities define the greatest force or load a product can carry under usual environmental conditions. Shock loading and extraordinary conditions must be taken into account when selecting products.

The products in the Bishop Lifting Products, Inc. catalog are fabricated by combining rigging hardware, wire rope, synthetic webbing, synthetic tubing, alloy chain, and metal mesh. Some slings will have components supplied from several different manufacturers. It is critical that you read and understand the literature from these manufactures, as well as governmental standards and industry technical manuals.

The rated capacity, design factor, and efficiency rating of each Bishop Lifting Products, Inc. product may be affected by wear, misuse, overloading, corrosion, deformation, intentional alteration, age, and other use conditions.

The recommended proof load on all items in this catalog is 2 times the rated capacity, unless otherwise shown. Proof testing is included on all Alloy Chain Slings, Metal Mesh Slings, Socket Lines, and Twin-Path® Products. Proof testing of other slings is optional, and is available upon request. Proof test certificates can also be stored, tracked, printed, and can now be e-mailed using our BLP QuickTrack™ online service at www.Lifting.com

Terms and Conditions

Product Quality

Bishop Lifting Products, Inc. warrants that products fabricated by Bishop Lifting Products, Inc. are, at the time of delivery, free of material and workmanship defects.

No warranty is made nor implied on any product which has been:

- Repaired or altered in such a way, in Bishop Lifting Products, Inc.'s judgment, as to affect the product adversely;
- Been subjected to negligence, accident, or improper storage or use;
- Not been operated and maintained in accordance with normal practice and in conformity with recommendation and published specifications of Bishop Lifting Products, Inc., ASME or current industry standards.

Returns, Cancellations, or Refunds

Due to the varying lengths of slings, most are non-stock items. Orders shall not be subject to cancellation, returns, refunds, or modification, either in whole or in part, without Bishop Lifting Products, Inc.'s written consent.

Types of Payment

Accounts may be established with Bishop Lifting Products, Inc. after submitting an application for credit. After it has been processed, a credit limit or status may be established, and the customer will be notified. Bishop Lifting Products, Inc. also accepts cash, credit cards, and in our online store excepts all payments processed by PayPal.™

Terms of Payment

Net 30 is standard terms of payment. Past due accounts may be subject to a hold on shipments.

Shipping

Bishop Lifting Products, Inc. reserves the right to include shipping and delivery charges, as well as fuel surcharges. Contact your Bishop Lifting Products, Inc. branch for local delivery range and information. Bishop Lifting Products, Inc. also offers many freight options for locations outside our branch ranges.

Minimum Order Charge

Orders less than \$100 will be subject to a special handling charge of \$25, exceptions are limited to repair parts.

Eliminate Paperwork with Mobile Tracking & Inspection Technology

Bishop Lifting Products, Inc. has partnered with the industry's leading RFID provider INFOCHIP® Systems, Inc. to deliver an innovative solution that streamlines your inspection, maintenance, certification, and tracking processes. Mobile computing, Radio Frequency (RFID) tagging and internet applications provide enhanced accuracy and operational efficiency to you and your extended team while eliminating most of the paperwork.

- Serial Number or Radio Frequency ID (RFID) tracking
- Chips are embedded in items or attached in durable housings
- Accurate, detailed and immediate identification
- Comprehensive web application and database features inspection alerts, certificates, asset history, etc.
- User-customizable inspection forms for any field task
- Schedule inspections, maintenance & repairs automatically
- Streamline digital inventory counts, balances and location tracking
- Online reports alert you to needed repairs or work order data
- Utilized by inspection service teams and end-customers
- Fully integratable to work order and test systems, eliminating data re-entry



Track any type of equipment for certification and maintenance:
Rigging, Valves, Pumps, Tools, Pipe, Vehicles, Anything...



Introducing BLP QuickTrack™

What is it?

BLP QuickTrack™ is an online solution designed to help customers manage assets and associated documentation, i.e. proof test certificates, inspection forms, pictures, notes, etc.

How does it work for me?

BLP QuickTrack™ Online – online access to a secure web portal designed for quick and easy management of asset information

BLP QuickTrack™ Desktop – for customers who want greater control of their asset management program by installing software on local computers which synchronize with BLP QuickTrack Online.

BLP QuickTrack™ Mobile – all the benefits to BLP QuickTrack Desktop in the palm of your hand.

Why do I need it?

- Improves Asset Tracking & Logistics
- Stores written inspection records per ASME B30 Standards
- Reduce total asset management cost
- Accurate Budgeting & Forecasting
- E-Mailed reminders for Inspections, Preventive Maintenance and Replacements
- Custom Exception Reporting
- Instant Positive Identification

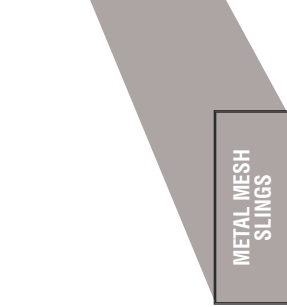
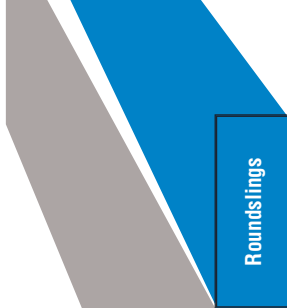
When can we start?

- Contact Customer Service at the Bishop Lifting Products, Inc. branch in your area for details
- Determine the program that works best for your company
 - ◆ BLP QuickTrack™ Online
 - ◆ BLP QuickTrack™ Online & Desktop
 - ◆ BLP QuickTrack™ Online, Desktop and Mobile
- E-Mail blpquicktrack@lifting.com
- Call 800-972-1041

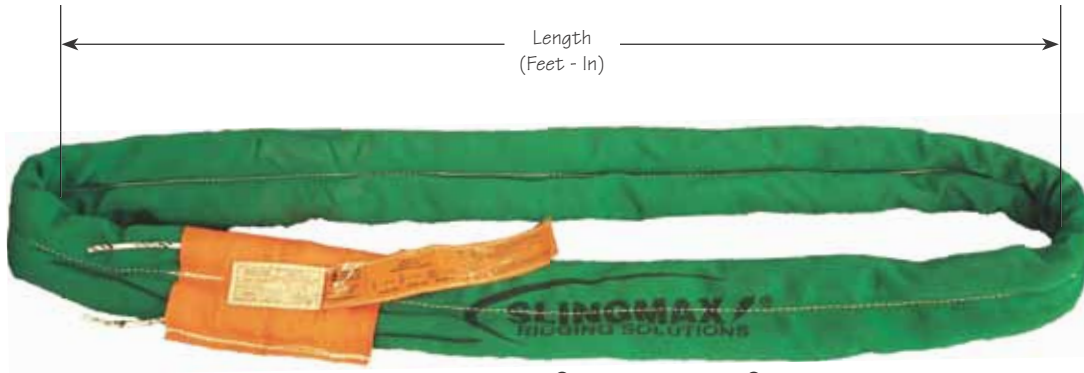


Table of Contents

SlingMax® Rigging Solutions	7
• Mechanical Considerations	26
• Environmental Considerations	27
• Fiber Characteristics	28
• Inspections of Twin-Path® Products	29
• Test Procedures of Twin-Path® Products	29
• Reference.....	30
Wire Rope Slings	31
• Wire Rope Sling Warnings	58
• Identification, Inspection, Rigging Practices	59
• Weight Tables	61
Alloy Chain Slings	67
• Coupling Types.....	68
• Warnings	83
• Identification, Inspection, Rigging Practices	84
• Important Terms.....	87
• Weight Tables	88
Web Slings	93
• Warnings	115
• Identification, Inspection, Rigging Practices	116
• How to Order	118
• Weight Tables	119
Roundslings	123
• Warnings	130
• Identification, Inspection, Rigging Practices	131
• Weight Tables	132
Metal Mesh Slings	133
• Warnings	136
• Dimensional Data	137
• Weight Tables	137
• Chemical Environment Data.....	137
• Identification, Inspection, and Rigging Practices	138
Technical Information.....	140
• Definitions of Terms	140
• Basic Lift Engineering.....	141
• Rigging Information.....	142
• Weights of Material.....	144
• Formulas and Information.....	144
• Conversion Tables	145
Training Aids.....	146
• Rigging Hardware.....	146
• Hitches & Capacities.....	148
• Crane Hand Signals	150







TPXC – Twin-Path[®] Extra Covermax[®]
sling with K-Spec core yarn

Features:

- The lightest and strongest sling on the market today
- Heavy duty bulked nylon, 2 ply, 2 path, outer cover with superior abrasion resistance
- Overload tell-tails and a fiber optic internal inspection system
- Red inner cover provides an early warning safety alert
- 10% the weight of a wire rope sling of comparable length and capacity
- Repairable
- 1% stretch at rated capacity
- Proof tested to 2X rated capacity
- Design factor 5 to 1

How to order:

- Combine model and length X (*)

Part Number		Rated Capacities in Lbs.					Approx. Weight per foot (bearing to bearing)	Nominal Body Width
Model	Length	Vertical	Choker	90° Basket	60° Basket	45° Basket		
TPXC 1000	X *	10,000	8,000	20,000	17,320	14,140	.40	1.5 - 3"
TPXC 1500	X *	15,000	12,000	30,000	25,980	21,210	.45	1.5 - 3"
TPXC 2000	X *	20,000	16,000	40,000	34,640	28,280	.51	1.5 - 3"
TPXC 2500	X *	25,000	20,000	50,000	43,300	35,350	.57	1.5 - 3"
TPXC 3000	X *	30,000	24,000	60,000	51,960	42,420	.71	2 - 4"
TPXC 4000	X *	40,000	32,000	80,000	69,280	56,560	.83	2 - 4"
TPXC 5000	X *	50,000	40,000	100,000	86,600	70,700	1.14	2.5 - 5"
TPXC 6000	X *	60,000	48,000	120,000	103,920	84,840	1.27	2.5 - 5"
TPXC 7000	X *	70,000	56,000	140,000	121,240	98,980	1.39	2.5 - 5"
TPXC 8500	X *	85,000	68,000	170,000	147,220	120,190	1.65	3 - 6"
TPXC 10000	X *	100,000	80,000	200,000	173,200	141,400	1.84	3 - 6"
TPXC 12500	X *	125,000	100,000	250,000	216,500	176,750	2.35	4 - 8"
TPXC 15000	X *	150,000	120,000	300,000	259,800	212,100	2.66	4 - 8"
TPXC 17500	X *	175,000	140,000	350,000	303,100	247,450	3.14	5 - 10"
TPXC 20000	X *	200,000	160,000	400,000	346,400	282,800	3.45	5 - 10"
TPXC 25000	X *	250,000	200,000	500,000	433,000	353,500	4.07	5 - 10"
TPXC 27500	X *	275,000	220,000	550,000	476,300	388,850	4.61	6 - 12"
TPXC 30000	X *	300,000	240,000	600,000	519,600	424,200	4.92	6 - 12"
TPXC 40000	X *	400,000	320,000	800,000	692,800	565,600	6.54	7 - 14"
TPXC 50000	X *	500,000	400,000	1,000,000	866,000	707,000	8.15	8 - 16"

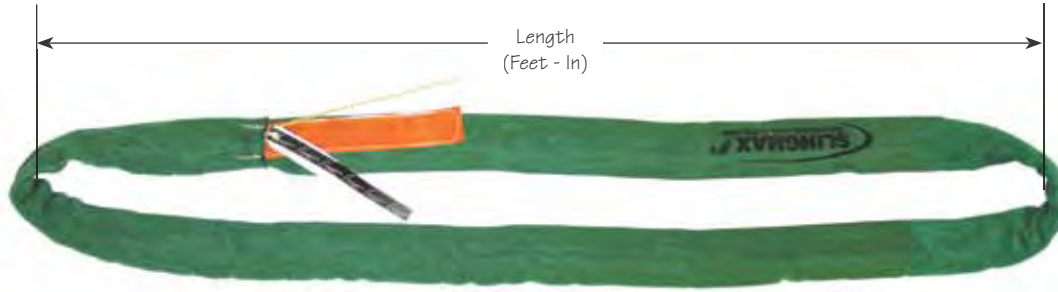
Note:

- Capacities shown include both paths and are for one complete sling
- Sling rating based on fittings of equal or greater capacity
- Conforms to ASME B30.9, NAVFAC P-307 section 14.6.4.3, and the Cordage Institute Roundsling standard



WARNING

Sling can fail or be damaged, misused or overloaded. Inspect before each use. Damaged sling shall not be used. Use only if trained. Do not exceed the rated capacity. Protect the sling from being cut by load edges, corners, protrusions and abrasive surfaces. Avoid exposure to acid, alkali and temperatures over 180°F. DEATH or INJURY can occur from improper maintenance.



SPXC – Single-Path[®] Extra Covermax[®]
sling with K-Spec core yarn and ✓Fast[™] system

Features:

- ✓Fast[™] external warning indicator (EWI) provides a pass/ fail indication of the internal load bearing core yarns
- Heavy duty bulked nylon, 2 ply, 1 path, outer cover with superior abrasion resistance
- Overload tell-tails and a fiber optic internal inspection system
- Design factor 5 to 1
- Red inner cover provides an early warning safety alert
- 10% the weight of a wire rope sling of comparable length and capacity
- Repairable
- 1% stretch at rated capacity
- Proof tested to 2X rated capacity

How to order:

- Combine model and length X (*)

Part Number		Rated Capacities in Lbs.					Approx. Weight per foot (bearing to bearing)	Nominal Body Width
Model	Length	Vertical	Choker	90° Basket	60° Basket	45° Basket		
SPXCF 500	X *	5,000	4,000	10,000	8,660	7,070	.34	1 – 2"
SPXCF 1000	X *	10,000	8,000	20,000	17,320	14,140	.38	1 – 2"
SPXCF 1500	X *	15,000	12,000	30,000	25,980	21,210	.44	1 – 2"
SPXCF 2000	X *	20,000	16,000	40,000	34,640	28,280	.52	1 – 2"
SPXCF 2500	X *	25,000	20,000	50,000	43,300	35,350	.59	1.5 – 3"
SPXCF 3000	X *	30,000	24,000	60,000	51,960	42,420	.65	1.5 – 3"
SPXCF 4000	X *	40,000	32,000	80,000	69,280	56,560	.85	2 – 4"
SPXCF 5000	X *	50,000	40,000	100,000	86,600	70,700	.98	2 – 4"
SPXCF 6000	X *	60,000	48,000	120,000	103,920	84,840	1.11	2 – 4"
SPXCF 7000	X *	70,000	56,000	140,000	121,240	98,980	1.24	2 – 4"
SPXCF 8500	X *	85,000	68,000	170,000	147,220	120,190	1.63	2.5 – 5"
SPXCF 10000	X *	100,000	80,000	200,000	173,200	141,400	1.81	2.5 – 5"

Note:

- Sling rating based on fittings of equal or greater capacity
- Patent pending 60/683,987

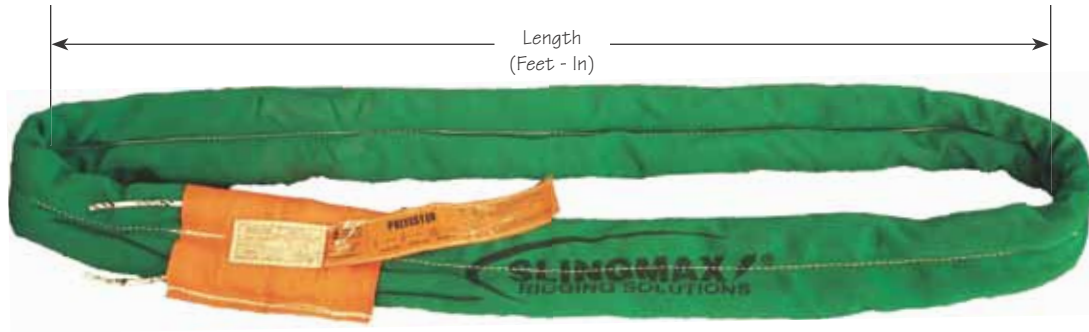
Instructions for ✓Fast[™] Inspection:

- Read the tag information on the sling tag to identify the rated capacity of the hitch being use, then type of cover and core, the manufacturer's name, and the warning and instructions on the bag. Be sure the information complies with existing standards
- Inspect the circumference of the sling for holes, tears, and other damage to the outer cover. If damage is discovered, take the sling out of service and send it in for evaluation. Do not use the sling.
- Visually inspect the External Warning Indicator and the ✓Fast[™] tag. If both extend past the cover, the inspection is complete.
- If the EWI is missing, the result of internal failure, the ✓Fast[™] tag will pull out easily from the sling. If the EWI is missing because it was pushed inside the cover or cut off, the ✓Fast[™] tag will be secure when pulled on by the inspector



WARNING

Sling can fail or be damaged, misused or overloaded. Inspect before each use. Damaged sling shall not be used. Use only if trained. Do not exceed the rated capacity. Protect the sling from being cut by load edges, corners, protrusions and abrasive surfaces. Avoid exposure to acid, alkali and temperatures over 180°F. DEATH or INJURY can occur from improper maintenance.



TPC – Twin-Path[®] Covermax[®]
sling with Polyester core yarn

Features:

- Heavy duty bulked nylon cover
- 2 ply - 2 path outer cover with superior abrasion resistance
- Red inner cover provides an early warning safety alert
- Repairable
- Proof tested to 2X rated capacity
- Design factor 5 to 1

How to order:

- Combine model and length X (*)

Part Number		Rated Capacities in Lbs.					Approx. Weight per foot (bearing to bearing)	Nominal Body Width
Model	Length	Vertical	Choker	90° Basket	60° Basket	45° Basket		
TPC200	X *	2,000	1,600	4,000	3,464	2,828	.28	2"
TPC 300	X *	3,000	2,400	6,000	5,196	4,242	.30	2"
TPC 450	X *	4,500	3,600	9,000	7,794	6,383	.45	2"
TPC 600	X *	6,000	4,800	12,000	10,392	8,484	.48	3"
TPC 750	X *	7,500	6,000	15,000	12,990	10,605	.65	3"
TPC 900	X *	9,000	7,200	18,000	15,588	12,726	.70	3"
TPC 1200	X *	12,000	9,600	24,000	20,784	16,968	.90	4"
TPC 1400	X *	14,000	11,200	28,000	24,248	19,796	.95	4"
TPC 1700	X *	17,000	13,600	34,000	29,444	24,038	1.20	4"
TPC 2200	X *	22,000	17,800	44,000	38,104	31,108	1.40	5"
TPC 2600	X *	26,000	20,800	52,000	45,032	36,764	1.70	5"
TPC 3200	X *	32,000	25,600	64,000	55,424	45,248	1.90	5"
TPC 5000	X *	50,000	40,000	100,000	86,600	70,700	2.70	6"
TPC 6000	X *	60,000	48,000	120,000	103,920	84,840	3.00	6"

Note:

- Capacities shown include both paths and are for one complete sling
- Sling rating based on of equal or greater capacity
- U.S. Patent # 4,850,629
- Canadian Patent # 1,280,458
- Italian Patent # 97300367.6
- Japanese Patent # 2929431



Sling can fail or be damaged, misused or overloaded. Inspect before each use. Damaged sling shall not be used. Use only if trained. Do not exceed the rated capacity. Protect the sling from being cut by load edges, corners, protrusions and abrasive surfaces. Avoid exposure to acid, alkali and temperatures over 180°F. DEATH or INJURY can occur from improper maintenance.



TPSE – Twin-Path[®] Sparkeater[®]
sling with Aramid high performance core yarn

Features:

- For hot environments up to 300°F
- Optional black cover for stage rigging applications
- Red inner cover provides an early warning safety alert
- 2 ply - 2 path outer cover with superior abrasion resistance
- Repairable
- Proof tested to 2X rated capacity
- Design factor 5 to 1

How to order:

- Combine model and length X (*)

Part Number		Rated Capacities in Lbs.					Approx. Weight per foot (bearing to bearing)	Nominal Body Width
Model	Length	Vertical	Choker	90° Basket	60° Basket	45° Basket		
TPSE 1000	X *	10,000	8,000	20,000	17,320	14,140	.31	3"
TPSE 2000	X *	20,000	16,000	40,000	34,640	28,280	.55	3"
TPSE 3000	X *	30,000	24,000	60,000	51,960	42,420	.80	4"

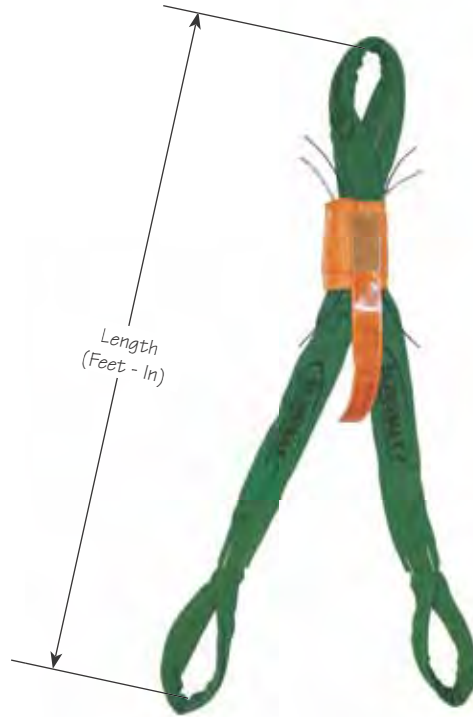
Note:

- Capacities shown include both paths and are for one complete sling
- Sling rating based on fittings of equal or greater capacity
- U.S. Patent # 4,850,629
- Canadian Patent # 1,280,458



WARNING

Sling can fail or be damaged, misused or overloaded. Inspect before each use. Damaged sling shall not be used. Use only if trained. Do not exceed the rated capacity. Protect the sling from being cut by load edges, corners, protrusions and abrasive surfaces. Avoid exposure to acid, alkali and temperatures over 300°F. DEATH or INJURY can occur from improper maintenance.



TPXCTL – Twin-Path[®] two leg bridle
with K-Spec[®] core yarn

Features:

- The lightest and strongest bridles in the world
- No heavy steel ring to deal with
- Red inner cover provides an early warning safety alert
- 2 ply - 2 path outer cover with superior abrasion resistance
- Repairable
- Proof tested to 2X rated capacity
- Design factor 5 to 1

How to order:

- Combine model and length X (*)

Part Number		Rated Capacities in Lbs.			Approx. Weight per foot	Nominal Body Width
Model	Length	Both Legs Vertical	60° Basket	45° Basket		
TPXCTL 1000	X *	10,000	8,500	7,000	.34	3"
TPXCTL 1500	X *	15,000	12,750	10,500	.44	3"
TPXCTL 2000	X *	20,000	17,000	14,000	.61	3"
TPXCTL 3000	X *	30,000	25,500	21,000	.88	4"
TPXCTL 4000	X *	40,000	34,000	28,000	1.23	5"
TPXCTL 5000	X *	50,000	42,500	35,000	1.65	5"

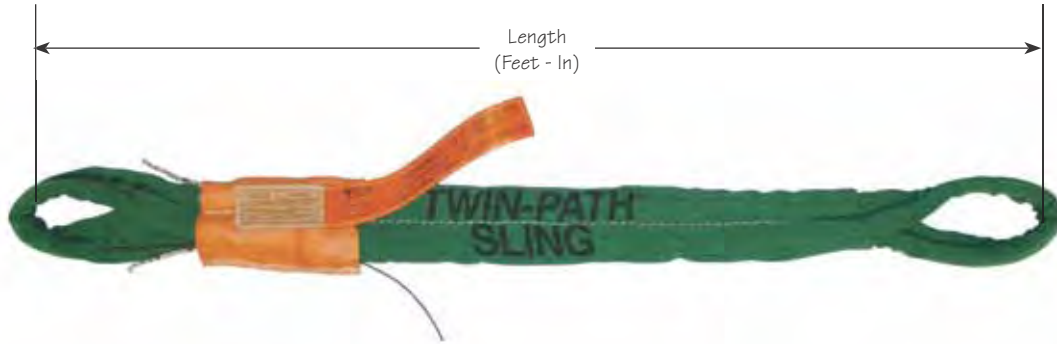
Note:

- Capacities shown are for both legs being loaded equally
- Sling rating based on fittings of equal or greater capacity
- U.S. Patent # 5,727,833 & # 4,850,629



WARNING

Sling can fail or be damaged, misused or overloaded. Inspect before each use. Damaged sling shall not be used. Use only if trained. Do not exceed the rated capacity. Protect the sling from being cut by load edges, corners, protrusions and abrasive surfaces. Avoid exposure to acid, alkali and temperatures over 180°F. DEATH or INJURY can occur from improper maintenance.



TPXCEE – Twin-Path[®] eye & eye sling
with K-Spec[®] core yarn

Features:

- For applications where an eye & eye sling is preferred
- The lightest and strongest sling on the market today
- Heavy duty bulked nylon
- Overload tell-tails and a fiber optic internal inspection system
- Red inner cover provides an early warning safety alert
- 2 ply - 2 path outer cover with superior abrasion resistance
- Repairable
- Proof tested to 2X rated capacity
- Design factor 5 to 1

How to order:

- Combine model and length X (*)

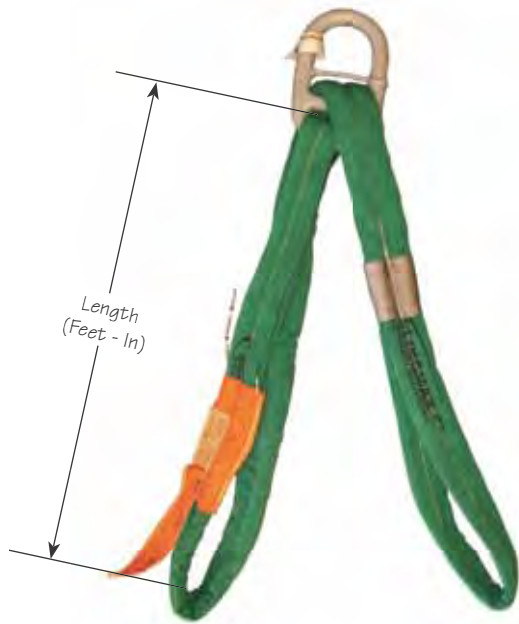
Part Number		Rated Capacities in Lbs.			Approx. Weight per foot	Nominal Body Width
Model	Length	Vertical	Choker	Basket		
TPXCEE 1000	X *	10,000	8,000	20,000	.28	3"
TPXCEE 1500	X *	15,000	12,000	30,000	.36	3"
TPXCEE 2000	X *	20,000	16,000	40,000	.50	3"
TPXCEE 2500	X *	25,000	20,000	50,000	.60	4"
TPXCEE 3000	X *	30,000	24,000	60,000	.75	4"
TPXCEE 4000	X *	40,000	32,000	80,000	1.00	5"
TPXCEE 5000	X *	50,000	40,000	100,000	1.40	5"

Note:

- Capacities shown are for both legs being loaded equally
- Sling rating based on fittings of equal or greater capacity
- U.S. Patent # 5,727,833 & # 4,850,629



Sling can fail or be damaged, misused or overloaded. Inspect before each use. Damaged sling shall not be used. Use only if trained. Do not exceed the rated capacity. Protect the sling from being cut by load edges, corners, protrusions and abrasive surfaces. Avoid exposure to acid, alkali and temperatures over 180°F. DEATH or INJURY can occur from improper maintenance.



If the lifting points are an equal distance from the center of gravity then the Twin-Path[®] Adjustable can be hooked-up with the double or single sling on either lifting point.



If the lifting points are an equal distance on either side of the center of gravity but one is higher, then the double sling should be attached to the higher lifting point.



If one of the lifting points is closer to the center of gravity, then attach the double sling to this lifting point. It will have the highest weight concentration. If the Twin-Path[®] Adjustable is attached so that the single sling is nearest the center of gravity, it will not allow the lift to be made.



Never use the Twin-Path[®] Adjustable Bridle in situations where the sling-to-hook angle is greater than 45°. Always connect above the center of gravity. If connections are made below the center of gravity, then the load may turn when lifted.

TPA – Twin-Path[®] adjustable bridle with polyester core yarn
TPXA – Twin-Path[®] adjustable bridle with K-Spec[®] core yarn

Features:

- Ultimate multiple use rigging tool
- Self adjusts to the center of gravity
- Heavy duty bulked nylon, 2 ply, 2 path, outer cover with superior abrasion resistance
- Overload tell-tails and a fiber optic internal inspection system
- Red inner cover provides an early warning safety alert
- Repairable
- Proof tested to 2X rated capacity
- Design factor 5 to 1

How to order:

- Combine model and length X (*)

Part Number		Bridle Capacity	Shackles		Approx. Weight per foot		Nominal Body Width
Model	Length		Shackle Sizes	Rated Capacity tons	3' base	Adder per ft.	
TPA 6	X *	6,000	5/8"	3-1/4	4.4	1.35	2"
TPXA 12	X *	12,000	7/8"	6-1/2	6.8	1.95	3"
TPXA 20	X *	20,000	1-1/4"	12	13.6	2.7	4"
TPXA 40	X *	40,000	1-3/4"	25	31.1	4.2	5"
TPXA 60	X *	60,000	2"	35	60	5.7	5"
TPXA 90	X *	90,000	2-1/4"	55	86	8.1	6"

Note:

- Capacities shown are for entire bridle assembly with legs at 45° angle
- Sling rating based on fitting of equal or greater capacity
- U.S. Patent # 4,850,629
- Canadian Patent # 1,280,458



Sling can fail or be damaged, misused or overloaded. Inspect before each use. Damaged sling shall not be used. Use only if trained. Do not exceed the rated capacity. Protect the sling from being cut by load edges, corners, protrusions and abrasive surfaces. Avoid exposure to acid, alkali and temperatures over 180°F. DEATH or INJURY can occur from improper maintenance.

FIBER OPTIC INSPECTION FOR ALL TWIN-PATH[®] SLINGS

US Patent #4,850,629 #5,651,572 Canadian Patent #1,280,458 #2,195,393
Italian Patent #97300367.6 Japanese Patent #2929431 Australian Patent #707924

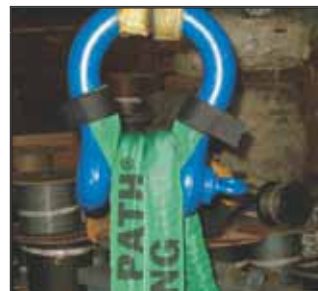
Twin-Path[®] slings have the Fiber Optic inspection system. The condition of the internal core yarn can be inspected just by checking the continuity of the fiber optic cable. If crushing or cutting, heat or chemical damage, has occurred then the damage to the fiber optic cable will destroy its ability to transmit light from one end to the other giving the inspector a reason to remove the sling from service and send it in for repair evaluation. The fiber optic cable will conduct light using natural, overhead or flashlight sources. The inspector simply covers and removes his finger from one end and watches the other end for blinking which indicates that the sling is OK to use for another lift.



SHACKLE PIN PADS

Patent Pending

The pin area of a shackle can cause synthetic slings to cut and placing synthetic slings on the pin should be avoided. Even a new shackle can have a sharp edge where the threaded pin goes through the shackle ear. If the sling is exposed to this area, it can cut and fail. The Shackle Pin Pad is the latest SLINGMAX[®] SOLUTION in the constant effort to ensure the ultimate rigging safety of our customers. If you must rig on the pin, protect your sling with a SLINGMAX[®] Pin Pad.



- Protects sling along entire pin including ear seams
- Three connection points secure pad to shackle
- Take on and off in seconds

⚠ WARNING

Can cause damage or failure of sling if misused or damaged. Inspect before each use. Inspect for cuts, tears, or damage that may prevent protection of the sling. Be sure wear protection is the correct size and type to protect the sling. DEATH or INJURY can occur from improper use or maintenance.

Synthetic Armor Pads protect the slings from abrasion damage which can be caused by contact with rough surfaces such as concrete beams and structures. They are also used to protect finished or painted loads from marring. These wear pads can be made to fit any length or width sling. They can also be made in long lengths which the customer can cut into suitable sizes on the job. Double or triple thickness provides resistance for the more severe conditions. There is no maximum width and a variety of materials are used to protect slings and to protect loads.

SYNARM-SL – Synthetic Armor Pad

Sliding type, 2 ply heavy duty tubing both sides, filled with white felt, with ends open

Features:

- Protects the sling from localized abrasion
- Extra Heavy duty Covermax[®] tubing
- 3/8" high density white felt filled both sides
- Can slide on the sling and be positioned in a specific location

How to order:

- Combine model and length



Part Number		Width	Sling Width
Model	Length		
03SYNARM-SL	*	3"	1"
04SYNARM-SL	*	4"	2"
06SYNARM-SL	*	6"	3"
08SYNARM-SL	*	8"	4"
10SYNARM-SL	*	10"	6"
12SYNARM-SL	*	12"	8"

SYNARM-RM – Synthetic Armor Pad

Removable type, 2 ply tubing both sides, filled with white felt, with Velcro closure one side

Features:

- Protects the sling from localized abrasion
- Extra Heavy duty Covermax[®] tubing
- 3/8" high density white felt filled both sides
- Easily attached and removed with the Velcro closure
- Can slide on the sling and be positioned in a specific location
- Larger widths available upon request

How to order:

- Combine model and length



Part Number		Width	Sling Width
Model	Length		
03SYNARM-RM	*	3"	1"
04SYNARM-RM	*	4"	2"
06SYNARM-RM	*	6"	3"
08SYNARM-RM	*	8"	4"
10SYNARM-RM	*	10"	6"
12SYNARM-RM	*	12"	8"

SYNARM-EE – Synthetic Armor Pad

Eye and eye type, 2 ply tubing both sides, filled with white felt, with installation and removal handles each end.

Features:

- Fits over both legs of an endless sling to enable it to be used like an eye and eye sling
- Protects the sling from localized abrasion
- Extra Heavy duty Covermax[®] tubing
- 3/8" high density white felt filled both sides
- Handle sewn each end
- Larger widths available upon request

How to order:

- Combine model and length



Part Number		Width	Sling Width
Model	Length		
03SYNARM-EE	*	3"	1"
04SYNARM-EE	*	4"	2"
06SYNARM-EE	*	6"	3"
08SYNARM-EE	*	8"	4"
10SYNARM-EE	*	10"	6"
12SYNARM-EE	*	12"	8"



CRNMX – CornerMax™ Pad

Edge protection, 1 ply web filled with 3/4" nylon rods, with 2 Velcro closures

Features:

- CornerMax™ Pad forms a tunnel between the load edge and the pad
- Position on corners or edges of the load
- Pad protects sling because of zero contact
- Filled with 3/4" nylon round bars
- Easily attached and removed with the Velcro closure
- Custom widths and sizes available upon request

How to order:

- Specify part number

Part Number	Width	Sling Width
CRNMX02	4"	Up to 2"
CRNMX03	5"	3"
CRNMX04	6"	4"
CRNMX05	8"	5"
CRNMX06	8"	6"
CRNMX08	10"	8"
CRNMX10	12"	10"





G-Link™ Synthetic Sling Connector

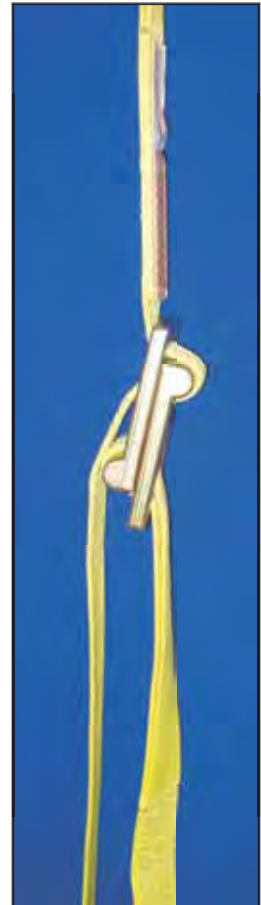
Features:

- Couples web, round, or Twin-Path[®] slings with hardware (oblongs or hooks)
- Splices two slings into longer length
- Connects two slings with oblong and two hooks into bridle sling
- Allows sling to be used as sliding choker sling
- Two G-Link™ connectors used together will double the rated capacity of one G-Link™ connector
- Conforms with ASME B30.9 web and roundsling specifications
- Shortens sling reach

Model	Sling Size (in.)	Rated Capacities in Lbs.		Weight Lbs.
		Vertical	Choker	
SC200L	2	5,000	4,000	2
SC300L	3	10,000	6,000	3 1/2
SC400L	4	15,000	8,000	7
SC500L	5	30,000	16,000	15
SC600L	6	50,000	24,000	29

Note:

- US Patent #5,651,573
- Canadian Patent #2,198,821
- Italian Patent #97302680.0
- Japanese Patent #Hei9-94730
- Australian Patent #710067



Connect Hook or
Oblong to Sling



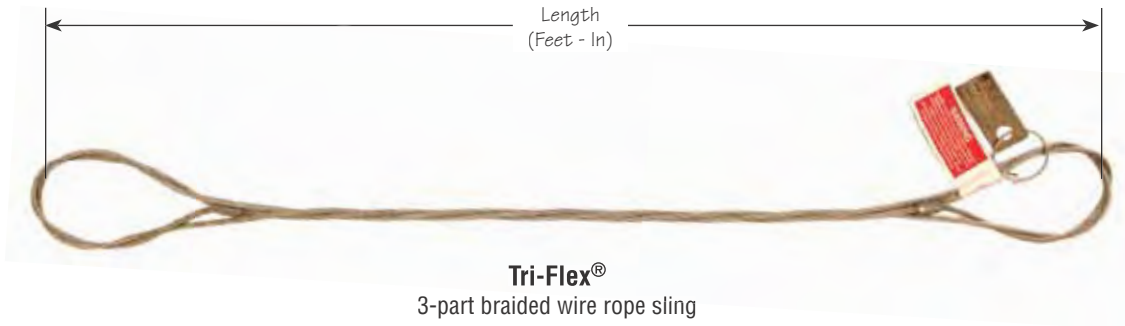
Choker Sling



Connect Two Slings

Shorten Slings

⚠ WARNING Can fail if damaged, misused or overloaded. Inspect before use. Use only if trained. Observe rated capacity. DEATH or INJURY can occur from improper use or maintenance.



Tri-Flex[®]
3-part braided wire rope sling

Features:

- Provides the best combination of strength and flexibility
- Heavy gauge stainless steel tag made in accordance with ASME B30.9 & API RP2C
- 6x19 class IWRC EIP bright wire rope supplied standard on 1/4" – 1-1/8"
- 6x37 class IWRC EIP bright wire rope supplied standard on 1-1/4" and larger
- D/d of the eye equals 2 to 1
- D/d of the body equals 5 to 1
- Proof testing available upon request
- Design factor 5 to 1

How to order:

- Specify part number and length

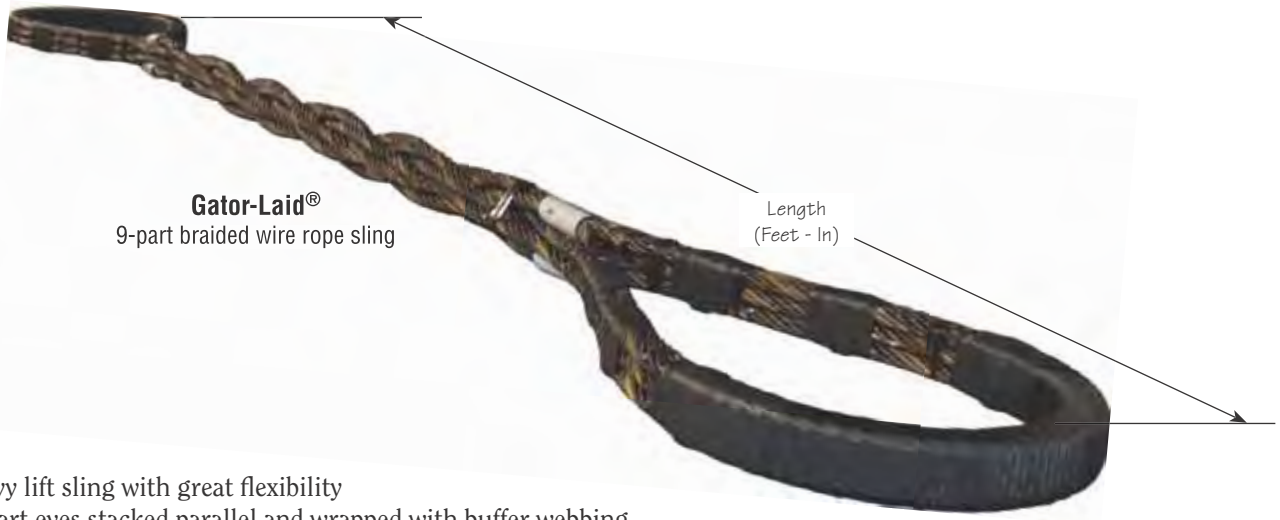
Composed of 3 parts of EIP Rope	Part Number	Actual Finished Diameter	Rated Capacities in Short Tons			Weight per foot. Lbs.
			Vertical	Choker	Vertical Basket	
1/4"	13010103	1/2"	1.7	1.3	3.4	.44
5/16"	13010104	5/8"	2.6	1.9	5.2	.68
3/8"	13010105	3/4"	3.6	2.7	7.2	.99
7/16"	13010106	7/8"	4.9	3.7	9.8	1.33
1/2"	13010107	1"	6.4	4.8	12.8	1.75
9/16"	13010108	1-1/8"	8.0	6.0	16.0	2.24
5/8"	13010109	1-1/4"	9.9	7.4	19.8	2.73
3/4"	13010110	1-1/2"	14.0	10.5	28.0	3.9
7/8"	13010111	1-3/4"	19.0	14.3	38.0	5.4
1"	13010112	2"	24.8	18.6	49.6	7.0
1-1/8"	13010113	2-1/4"	31.2	23.4	62.4	8.9
1-1/4"	13010114	2-1/2"	38.4	28.8	76.8	10.0
1-3/8"	13010115	2-3/4"	46.0	34.5	92.0	13.3
1-1/2"	13010116	3"	55.0	41.2	110.0	15.8
1-3/4"	13010118	3-1/2"	73.0	54.8	146.0	21.5
2"	13010120	4"	95.0	71.2	190.0	28.0
2-1/4"	13010122	4-1/2"	118.0	88.5	236.0	35.6
2-1/2"	13010124	5"	145.0	109.0	290.0	44.0

Note:

- Specify wire rope construction, grade, and finish if other than standard
- See reference page for additional D/d, minimum length, and features



Follow OSHA, ASME B30.9 and Manufacturer's Guidelines. Can fail if damaged, misused, or overloaded. Inspect before use. Use only if trained. Do not exceed rated capacity. Protect from contact with edges. DEATH or INJURY can occur from improper use or maintenance.



Features:

- Heavy lift sling with great flexibility
- 12 part eyes stacked parallel and wrapped with buffer webbing
- Heavy gauge stainless steel tag made in accordance with ASME B30.9 & API RP2C
- 6x19 class IWRC EIP bright wire rope supplied standard on 1/4" – 1-1/8"
- 6x37 class IWRC EIP bright wire rope supplied standard on 1-1/4" and larger
- D/d of the eye equals 1 to 1
- D/d of the body equals 5 to 1
- Proof testing available upon request
- Design factor 5 to 1

How to order:

- Specify part number and length

Composed of 9 parts of EIP Rope	Part Number	Actual Finished Diameter	Eye Length	Rated Capacities in Short Tons			Approximate Wt./ Ft. Lbs.
				Vertical	Choker	Vertical Basket	
1/8"	1L010101	1/2"	8"	1.4	.95	2.7	.26
3/16"	1L010102	5/8"	10"	1.8	1.4	3.6	.40
1/4"	1L010103	1"	16"	4.8	3.6	9.7	.99
5/16"	1L010104	1-1/4"	18"	7.4	5.5	14.7	1.56
3/8"	1L010105	1-1/2"	20"	10.5	7.9	21.0	2.19
7/16"	1L010106	1-3/4"	22"	14	11	29	3.15
1/2"	1L010107	2"	24"	19	14	38	4.14
9/16"	1L010108	2-1/4"	26"	24	19	48	5.31
5/8"	1L010109	2-1/2"	28"	29	22	58	6.48
3/4"	1L010110	3"	30"	42	31	83	9.36
7/8"	1L010111	3-1/2"	35"	56	42	112	12.78
1"	1L010112	4"	40"	74	55	146	16.65
1-1/8"	1L010113	4-1/2"	45"	92	69	184	21.06
1-1/4"	1L010114	5"	50"	113	85	227	26.01
1-3/8"	1L010115	5-1/2"	55"	137	102	273	31.50
1-1/2"	1L010116	6"	60"	162	121	323	37.44
1-3/4"	1L010118	7"	70"	216	162	432	51.03
2"	1L010120	8"	80"	280	210	560	66.51
2-1/4"	1L010122	9"	90"	350	261	700	84.24
2-1/2"	1L010124	10"	100"	428	321	856	104.00

Note:

- Specify wire rope construction, grade, and finish if other than standard
- See reference page for additional D/d, minimum length, and features
- U.S. Patent # 4,420,659 & 5,561,973



Follow OSHA, ASME B30.9 and Manufacturer's Guidelines. Can fail if damaged, misused, or overloaded. Inspect before use. Use only if trained. Do not exceed rated capacity. Protect from contact with edges. DEATH or INJURY can occur from improper use or maintenance.



Gator-Max[™]
9-part braided wire rope sling

Features:

- Strongest multi-part sling with great flexibility
- 12 part eyes stacked parallel and wrapped with buffer webbing
- Heavy gauge stainless steel tag made in accordance with ASME B30.9 & API RP2C
- 6x19 class IWRC EIP bright wire rope supplied standard on 1/4" – 1-1/8"
- 6x37 class IWRC EIP bright wire rope supplied standard on 1-1/4" and larger
- D/d of the eye equals 1 to 1
- D/d of the body equals 5 to 1
- Proof testing available upon request
- Design factor 5 to 1



How to order:

- Specify part number and length

Composed of 9 parts of EIP Rope	Part Number	Actual Finished Diameter	Eye Length	Rated Capacities in Short Tons			Approximate Wt./ Ft. Lbs.
				Vertical	Choker	Vertical Basket	
1/8"	1M010101	1/2"	8"	1.4	.95	2.7	.26
3/16"	1M010102	5/8"	10"	1.8	1.4	3.6	.40
1/4"	1M010103	1"	16"	4.8	3.6	9.7	.99
5/16"	1M010104	1-1/4"	18"	7.4	5.5	14.7	1.56
3/8"	1M010105	1-1/2"	20"	10.5	7.9	21.0	2.19
7/16"	1M010106	1-3/4"	22"	14	11	29	3.15
1/2"	1M010107	2"	24"	19	14	38	4.14
9/16"	1M010108	2-1/4"	26"	24	19	48	5.31
5/8"	1M010109	2-1/2"	28"	29	22	58	6.48
3/4"	1M010110	3"	30"	42	31	83	9.36
7/8"	1M010111	3-1/2"	35"	56	42	112	12.78
1"	1M010112	4"	40"	74	55	146	16.65
1-1/8"	1M010113	4-1/2"	45"	92	69	184	21.06
1-1/4"	1M010114	5"	50"	113	85	227	26.01
1-3/8"	1M010115	5-1/2"	55"	137	102	273	31.50
1-1/2"	1M010116	6"	60"	162	121	323	37.44
1-3/4"	1M010118	7"	70"	216	162	432	51.03
2"	1M010120	8"	80"	280	210	560	66.51
2-1/4"	1M010122	9"	90"	350	261	700	84.24
2-1/2"	1M010124	10"	100"	428	321	856	104.00

Note:

- Specify wire rope construction, grade, and finish if other than standard
- See reference page for additional D/d, minimum length, and features
- U.S. Patent # 5,561,973



WARNING

Follow OSHA, ASME B30.9 and Manufacturer's Guidelines. Can fail if damaged, misused, or overloaded. Inspect before use. Use only if trained. Do not exceed rated capacity. Protect from contact with edges. DEATH or INJURY can occur from improper use or maintenance.

Length
(Feet - In)
Measured from
bearing point to
bearing point



Gator-Flex[®]
9-part braided wire rope sling

Features:

- Nine-part body with crossing wires in the eyes so no wrapping is necessary
- Heavy gauge stainless steel tag made in accordance with ASME B30.9 & API RP2C
- 6x19 class IWRC EIP bright wire rope supplied standard on 7/16" to 1-1/4"
- 6x37 class IWRC EIP bright wire rope supplied standard on 1-1/4" and larger
- D/d of the eye equals 1 to 1
- D/d of the body equals 5 to 1
- Proof testing available upon request
- Design factor 5 to 1

How to order:

- Specify part number and length

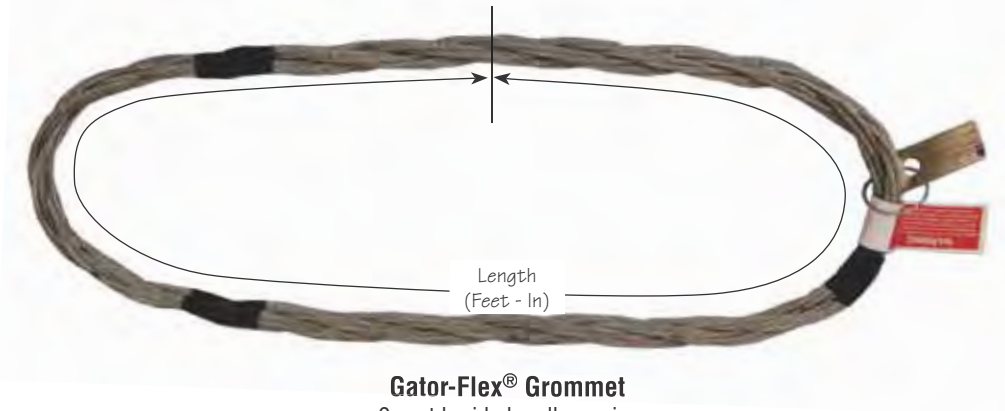
Composed of 9 parts of EIP Rope	Part Number	Actual Finished Diameter	Eye Length	Min. Length in Feet	Rated Capacities in Short Tons			Approximate Wt./Ft. Lbs.
					Vertical	Choker	Vertical Basket	
7/16"	1F010106	1-3/4"	22"	10.5	13.8	10.3	27.6	3.15
1/2"	1F010107	2"	24"	12.2	18.0	13.5	36	4.14
9/16"	1F010108	2-1/4"	26"	14.0	22.7	18.1	45.4	5.31
5/8"	1F010109	2-1/2"	28"	15.0	27.8	20.8	55.6	6.48
3/4"	1F010110	3"	30"	17.5	39.7	29.8	79.4	9.36
7/8"	1F010111	3-1/2"	35"	19.0	53.7	40.3	107.4	12.78
1"	1F010112	4"	40"	21.5	69.8	52.3	139.6	16.65
1-1/8"	1F010113	4-1/2"	45"	27.5	87.7	65.8	175.4	21.06
1-1/4"	1F010114	5"	50"	31.0	108.8	81.0	216	26.01
1-3/8"	1F010115	5-1/2"	55"	34.5	130	97.5	260	31.50
1-1/2"	1F010116	6"	60"	37.5	154	115.5	308	37.44
1-3/4"	1F010118	7"	70"	44.5	206	154.5	412	51.03
2"	1F010120	8"	80"	48.0	267	200.2	534	66.51
2-1/4"	1F010122	9"	90"	55.0	333	249.7	666	84.24
2-1/2"	1F010124	10"	100"	62.0	408	306	816	104.00

Note:

- Specify wire rope construction, grade, and finish if other than standard
- See reference page for additional D/d, minimum length, and features
- U.S. Patent # 5,561,973



Follow OSHA, ASME B30.9 and Manufacturer's Guidelines. Can fail if damaged, misused, or overloaded. Inspect before use. Use only if trained. Do not exceed rated capacity. Protect from contact with edges. DEATH or INJURY can occur from improper use or maintenance.



Gator-Flex[®] Grommet
9-part braided endless wire
rope sling

Features:

- Ultra flexible for heavy lifts
- Can be made shorter than standard multi-part slings
- Heavy gauge stainless steel tag made in accordance with ASME B30.9 & API RP2C
- 6x19 class IWRC EIP bright wire rope supplied standard on 1/4" – 1-1/8"
- 6x37 class IWRC EIP bright wire rope supplied standard on 1-1/4" and larger
- D/d of the body equals 5 to 1
- Proof testing available upon request
- Design factor 5 to 1

How to order:

- Specify part number and length

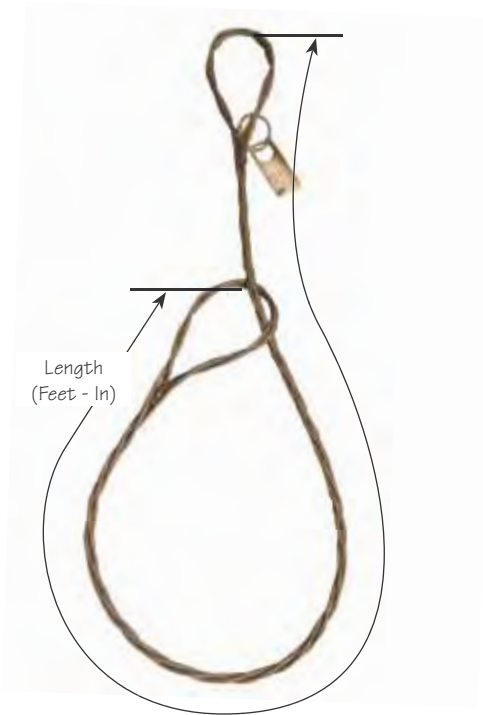
Dia Component parts	Part Number	Body Fin. Dia.	Rated Capacities in Short Tons			Approximate Wt./Ft. Lbs.
			Vertical	Choker	Basket	
1/4"	09595903	1"	10	7	20	1
5/16"	09595904	1-1/4"	15	11	30	1.62
3/8"	09595905	1-1/2"	22	15	44	2.35
7/16"	09595906	1-3/4"	29	21	58	3.15
1/2"	09595907	2"	38	27	76	4.15
9/16"	09595908	2-1/4"	48	34	96	5.31
5/8"	09595909	2-1/2"	59	42	118	6.48
3/4"	09595910	3"	85	59	170	9.36
7/8"	09595911	3-1/2"	115	81	230	13
1"	09595912	4"	148	104	296	17
1-1/8"	09595913	4-1/2"	187	131	374	21
1-1/4"	09595914	5"	230	161	460	26
1-3/8"	09595915	5-1/2"	276	194	552	32
1-1/2"	09595916	6"	328	230	656	38
1-3/4"	09595918	7"	441	308	882	51
2"	09595920	8"	570	399	1140	67
2-1/4"	09595922	9"	711	498	1422	84
2-1/2"	09595924	10"	870	609	1740	104
2-3/4"	09595925	11"	1040	728	2080	126
3"	09595927	12"	1224	857	2448	150

Note:

- Specify wire rope construction, grade, and finish if other than standard
- See reference page for additional D/d, minimum length, and features
- U.S. Patent # 5,561,973

⚠ WARNING

Follow OSHA, ASME B30.9 and Manufacturer's Guidelines. Can fail if damaged, misused, or overloaded. Inspect before use. Use only if trained. Do not exceed rated capacity. Protect from contact with edges. DEATH or INJURY can occur from improper use or maintenance.



T&D Ultra-Flex
9-part braided wire rope sling

Features:

- Extremely flexible and good for rigging applications in the utilities industry
- Forms a tight choke especially when lifting poles
- Heavy gauge stainless steel tag made in accordance with ASME B30.9 & API RP2C
- 7x19 galvanized cable supplied standard on 1/8" through 3/8"
- 6x19 class IWRC EIP bright wire rope supplied standard on 7/16" and larger
- D/d of the eye equals 1 to 1
- D/d of the body equals 5 to 1
- Proof testing available upon request
- Design factor 5 to 1

How to order:

- Specify part number and length

Composed of 3 parts of EIP Rope	Part Number	Actual Finished Diameter	Eye Length	Rated Capacities in Short Tons			Approximate Wt./ Ft.
				Vertical	Choker	Vertical Basket	
1/8"	1T010101	1/2"	8"	1.3	.9	2.6	.26
3/16"	1T010102	3/4"	12"	2.6	1.9	5.2	.59
1/4"	1T010103	1"	16"	4.6	3.4	9.2	.99
5/16"	1T010104	1-1/4"	18"	7.0	5.2	14.0	1.56
3/8"	1T010105	1-1/2"	20"	10	7.5	20	2.19
7/16"	1T010106	1-3/4"	22"	13.8	10.3	27.6	3.15
1/2"	1T010107	2"	24"	18	13.5	36.0	4.14

Note:

- Specify wire rope construction, grade, and finish if other than standard
- U.S. Patent # 5,561,973



Follow OSHA, ASME B30.9 and Manufacturer's Guidelines. Can fail if damaged, misused, or overloaded. Inspect before use. Use only if trained. Do not exceed rated capacity. Protect from contact with edges. DEATH or INJURY can occur from improper use or maintenance.



Chain Sling Saddle Ring
ALLOWS ADJUSTMENT OF CHAIN REACH

Features:

- Enables user to adjust the length of the legs
- No short adjustable legs needed
- Proof tested to 2X rated capacity
- Design factor of 4 to 1

System	Chain Size In.	Single Branch Sling 90° Loading	Rated Capacities in Lbs.					
			Double Sling			Triple and Quadruple Sling		
10	9/32"	4,300	7,500	6,100	4,300	11,200	9,100	6,450
10	3/8"	8,800	15,200	12,400	8,800	22,800	18,600	13,200
10	1/2"	15,000	26,000	21,200	15,000	39,000	31,800	22,500
10	5/8"	22,600	39,000	32,000	22,000	58,700	47,900	33,900
10	3/4"	35,300	61,100	49,900	35,300	91,700	74,900	53,000
10	7/8"	42,700	74,000	60,400	42,700	110,900	90,600	64,000
8	1"	47,700	82,600	67,400	47,700	123,900	101,200	71,500
8	1-1/4"	72,300	125,200	102,200	72,300	187,800	153,400	108,400
8	1-1/2"	80,000	138,600	113,100	80,000			

Notes:

- US Patent #4,241,575
- Canadian Patent #1,086,510
- British Patent #2,029,370



WARNING

Follow OSHA, ASME B30.9 and Manufacturer's Guidelines. Can fail if damaged, misused, or overloaded. Inspect before use. Use only if trained. Do not exceed rated capacity. Protect from contact with edges. DEATH or INJURY can occur from improper use or maintenance.

Mechanical Considerations

- Determine the weight of the load. The weight of the load shall be within the rated capacity of the sling.
- Select a sling having suitable characteristics for the type of load, hitch and environment.
- Slings shall not be loaded in excess of the rated capacity. Consideration shall be given to angle of lift which may affect the lifting capacity. Diameters of pins and edges also may affect the capacity of the lifting sling.
- Slings used in a choker shall not be forced to tighten around the load by pounding with hammers or other objects. Choker hitches are the least effective way to use a sling based on capacity. Two chokers should be used to balance the load. One choker in the center of the load may create an unbalanced situation which could lead to an accident.
- Slings used in a basket hitch must have the load balanced to prevent slippage and accidents.
- Slings used with fittings shall be compatible with the fittings used. The lifting capacity shall be rated at the lower of the fitting or sling. Fitting openings shall be of the proper shape and size to assure that the sling will seat properly.
- Slings shall be protected from cutting and edges. All protrusions and abrasive surfaces will be kept from contact with the sling. Where unavoidable situations develop, padding shall be placed between the sling and the load. **The pin area of a shackle can cause synthetic slings to cut and placing synthetic slings on the pin should be avoided unless it is protected.**
- Slings shall not be dragged on the floor or drawn across other surfaces which may damage the sling.
- Slings shall not be twisted or tied in knots to shorten.
- Slings shall not be pulled from under loads resting on the sling.
- Do not drop objects on slings or run over them with vehicles.
- Slings which are damaged shall not be used.
- Sling hitches must provide control of the load.
- Portions of the human body shall be kept from between the sling and the load and from between the sling and any attachment to lifting devices such as hooks.
- Personnel shall stand clear of suspended loads.
- Personnel shall not ride on the sling or suspended loads.
- Avoid snatch or shock loading.
- Twisting and kinking the legs of the sling shall be avoided.
- Load applied to the hook should be centered in the bowl of the hooks. Do not point load the hook.
- During lifting with or without the load all personnel shall be alert for possible snagging.
- The slings should contain or support the load from the sides above the center of gravity so that the load will not tilt when the load is lifted.
- Slings shall be of the proper length so that the angle of the sling to the load does not reduce the rated capacity of the sling for a given angle.
- Only legibly marked or labeled slings must be used. If the tag is not legible or missing, the sling must not be used.
- Keep labels or tags away from the load, the hook and the angle of choke.
- Slings should be inspected each time before each lift.

Environmental Considerations

When not in use, synthetic slings should be stored in a clean dry place. Heat sources and non-ventilated places should be avoided.

Chemically active environments can affect the strength of synthetic lifting slings. Different chemicals will react with different exposure to Covermax[®] bulked nylon, polyester, aramids, and olefins.

Aramids are resistant to most ketones, alcohols, dry cleaning solvents and many other organic solvents. Its acid resistance is superior to that of nylon but is not as good as that of polyester. Aramids show good resistance to alkalis at room temperature, but is degraded by strong alkalis at higher temperatures.

Aramids are compatible with fluorine-containing elastomers, resins, and refrigerants at high temperatures, and is resistant to fluorine compounds in concentrations usually encountered in stack gases from metallurgical and rock-processing operations.

The resistance of aramids to oxides of sulphur at temperatures above the acid dew point is superior to that of polyester. Below the dew point, concentrated sulphuric acid may condense on the fiber and cause a progressive loss in strength.

In moderate to strong acid or alkali environments, evaluation of aramids should be made to ensure that the yarn will perform acceptably before use.

Polyester and nylon are not significantly affected by most compounds of the following classes:

Alcohols, Dry Cleaning Solvents, Halogenated Hydrocarbons, Ketones, Soaps and Synthetic Detergents, and Water (Including Sea Water).

Polyester also shows good to excellent resistance to:

Aqueous solutions of most weak acids at the boil, and to most strong acids at room temperature, but is disintegrated by concentrated (95%) sulphuric acid at room temperature.

Aqueous solutions of strong alkalis at room temperature, but is degraded at the boil.

Oxidizing agents, and is not degraded by bleaching treatments ordinarily used for textiles.

Nylon is not significantly affected by most aldehydes, alkalis, ethers, or hydrocarbons, but is deteriorated by dilute acids (e.g., hydrochloric acid and sulphuric acid in 10% concentrations at room temperature cause a noticeable loss in breaking strength in 10 hours).

Solvents for nylon includes: Concentrated formic acid, Phenolic compounds at room temperature,

Calcium chloride in methanol at room temperature.

Hot solutions of calcium chloride in: Glacial Acetic Acid, Ethylene Chlorohydrin, Ethylene Glycol.

Hot solutions of zinc chloride in methanol Benzyl alcohol at the boil.

Aramids are resistant to most weak acids and alkalis, ketones, alcohols, hydrocarbons, oils and dry cleaning solvents. Strong acids and bases and sodium hypo-chlorite bleach attack aramids, particularly at high temperatures of high concentrations.

K-Spec[®] core yarn strength retention is based on test results of components at 65°C/150°F (or less) for 6 months. K-Spec[®] has a 100% strength retention when exposed to: Age, 10% detergent solution, rot and mildew, sunlight and Toluene; 99% strength retention when exposed to: acetic acid, gasoline, hydrochloric acid 1m, hydraulic fluid, kerosene, and sea water; 98% retention when exposed to: 25% ammonium hydroxide, 10% hypophosphite solution, and 40% phosphoric acid; 97% retention when exposed to 5m sodium hydroxide; 95% retention when exposed to Portland cement and sulphuric acid; and 88% retention when exposed to Clorox[®], and nitric acid.

Fiber Characteristics (Using Nylon as a basis of 1.0)

Generic Fiber Type	Nylon	Polyester	Polypropylene	HDPE Olefin	Aramid	K-Spec [®]
Bulk Strength ¹	1.0	.9-1.1	.55	2.8	2.7	2.75
Weight	1.0	1.21	.80	.85	1.26	1.01
Working ² Elastic Elongation	1.0	.60	.80	.10	.10	.10
Co-efficient ³ of Friction	.10-.12	.12- .15	.15-.22	.08	.10-.12	.10
					Chars at	Chars at
Melting Point	460°F	480°F	330°F	297°F	800°F	297°F
Critical ⁴ Temperature	180°F	180°F	180°F	150°F	300°F	180°F
Specific Gravity	1.14	1.38	.91	.97	1.44	1.2
Cold-Flow (Creep) ⁵	Negligible	Negligible	Negligible	Negligible to High	Negligible to High	Negligible

¹Bulk Strength is defined as strength per circumference squared.

²Working is defined as rope actually in use under a cycling load.

³Co-efficient of friction is based on reluctance to slip or slide.

⁴Critical temperature is defined as the point at which degradation is caused by temperature alone.

⁵Cold-Flow (Creep) is defined as fiber deformation (elongation) due to molecular slippage under a constant steady static loading situation. Fibers that have this inherent characteristic will display extremely low or negligible creep if minor fluctuations occur in the rate and/or frequency of load levels. In rope form, this would apply to polypropylene, polyethylene, and HDPE Olefin fibers.

Inspections of Twin-Path[®] Products

Tell-Tails should extend past the tag area of each sling. If both Tell-Tails are not visible, remove the sling from service. If any part of the sling shows evidence of chemical degradation, remove it from service. Send to manufacturer for repair evaluation.

Slings should be inspected for evidence of cutting or tearing of the outer cover. Slings with cuts should be removed from service and sent back to the manufacturer for repair evaluation. Damage to the cover may indicate core damage.

Inspect slings for evidence of heat damage. Aramid Sparkeater Slings should not be exposed to temperatures over 149°C/300°F. K-Spec[®] and Polyester Core Slings should not be exposed to temperatures above 82°C/180°F. Cold temperature exposure down to minus 40°C/minus 40°F do not effect the strength of the products. Other temperatures should be referred to the manufacturer.

Slings using aluminum fittings shall not be used where fumes, vapors, sprays, or mists of alkalis or acids are present.

Twin-Path[®] Lifting Slings and any fittings attached should be the subject of frequent and regular inspections. In addition to the initial inspection by a competent person and frequent written inspections, the slings should be visually inspected before each use.

Written inspections should be performed as required and documents of such inspection by a competent person shall be kept on file in the safety department of the plant or site where used. Inspections may be done more often based on frequency of use, severity of conditions, experience of past service life.

Slings should be examined throughout their length for abrasion, cuts, heat damage, fitting distortion or damage, tag legibility, and if any doubts are held by the inspector, the sling should be removed from service. Core integrity is determined by fiber optic light transfer if this type of tell-tail is installed in the sling. If a deterioration is found, the sling must be removed from service and returned to the manufacturer for evaluation.

Slings removed from service that are not capable of repair should be destroyed and rendered completely unfit for future use.

Abrasion, heat damage or cuts to the cover may indicate a loss of strength to the load core and these slings should not be used until evaluated by the manufacturer. At area of damage, cover should be opened and the core yarns counted and visually inspected.

Test Procedures for Complete Twin-Path[®] Sling Products

For proof testing, the pins shall be 1" diameter or larger.

Proof tests shall consist of pulling the slings to twice their rated capacity. Slings shall be held at the proof test limit for a minimum of 15 seconds and then the tension may be released.

Testing of Twin-Path[®] Sling products and load yarn shall be on a testing machine, which meets or exceeds the standards as described in ASME E-4.

Break testing of slings shall be as above with results documented. Pin size for break testing should be a diameter equal to half the nominal sling width or larger.

Proof testing is mandatory for every newly manufactured and repaired Twin-Path[®] sling.

After the sling is proof tested, the Tell-Tails should then be trimmed to length prior to shipment.

Repaired fittings or slings shall be proof-tested before they are returned to service.

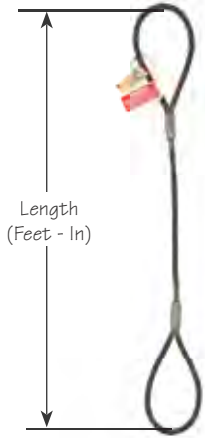
THESE RECOMMENDED STANDARD SPECIFICATIONS HAVE BEEN FORMULATED AS A GUIDE TO USERS, INDUSTRY AND GOVERNMENT TO INSURE THE PROPER USE, MAINTENANCE AND INSPECTION OF TWIN-PATH[®] LIFTING SLING PRODUCTS.

Quick reference chart of the most popular SLINGMAX[®] heavy-lift wire rope slings

	Parts of wire rope in body	D/d body*	D/d eye*	Termination of each eye	Min. Length	Features
Tri-Flex [®] sling 1	3	5/1	2/1	1 Ferrule	6' for 7/8" component wire*	Good replacement for single-strand wire rope slings
Gator-Laid [®] sling 2	9	5/1	1/1	3 Ferrules	6' for 3/4" component wire*	80% efficiency*; parallel-laid eyes
Gator-Max [™] sling 3	9	5/1	1/1	Hand tuck	15' for 1/2" component wire*	80% efficiency*; parallel-laid eyes
Gator-Flex [®] sling 4	9	5/1	1/1	Hand tuck	15' for 1/2" component wire*	Unwrapped eyes easy to inspect
Gator-Flex [®] grommet 5	9	5/1	N/A	Hand tuck	4' for 1/4" component wire*	Endless
		*Ratio based on finished body diameter	*Ratio based on finished body diameter		*Minimum length increases as component wire size increases	*90% efficiency slings and grommets available



Advantages: Flexibility, Low D/d ratios, fabrication to tight tolerances
Meets conditions specified by the Wire Rope Technical Board Sling Manual



BLP-100

Single leg sling with standard eyes each end



BLP-101

Single leg sling with standard eye one end and thimble eye other end



BLP-102

Single leg sling with thimble eye each end

Features:

- Flemished eye splice, not a Texas tucked or turn back eye splice
- Heavy gauge stainless steel tag in accordance with ASME B30.9 and API RP2D
- Quality controlled swaging process with paint verification
- 6x19 class IWRC EIP bright wire rope supplied standard on 1/4" – 1-1/8"
- 6x37 class IWRC EIP bright wire rope supplied standard on 1-1/4" and larger
- Proof testing available upon request
- Design factor 5 to 1

How to order:

- Specify part number and length in feet when ordering



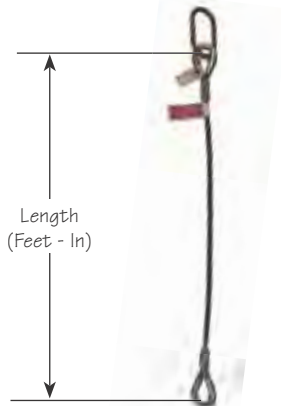
WARNING

See wire rope sling warnings page for warnings and inspection criteria

Dia. of Rope In.	Part Numbers			Min. Length ft'-in"	Standard Eye Dimensions		Rated Capacities in Short Tons		
	BLP-100	BLP-101	BLP-102		W"	L"	Choker Hitch	Vertical Hitch	Basket Hitch
1/4"	11010103	11010603	11060603	1-6	2	4	.48	.65	1.3
3/8"	11010105	11010605	11060605	2	3	6	1.1	1.4	2.8
1/2"	11010107	11010607	11060607	2-6	4	8	1.9	2.5	5.1
5/8"	11010109	11010609	11060609	3	5	10	2.9	3.9	7.8
3/4"	11010110	11010610	11060610	3-6	6	12	4.1	5.6	11.2
7/8"	11010111	11010611	11060611	4	7	14	5.6	7.6	15.2
1"	11010112	11010612	11060612	4-6	8	16	7.2	9.8	19.6
1-1/8"	11010113	11010613	11060613	5	9	18	9.1	12	24
1-1/4"	11010114	11010614	11060614	5-6	10	20	11	15	30
1-3/8"	11010115	11010615	11060615	6	11	22	13	18	36
1-1/2"	11010116	11010616	11060616	7	12	24	16	21	42
1-3/4"	11010118	11010618	11060618	8	14	28	21	28	56
2"	11010120	11010620	11060620	9	16	32	28	37	74
2-1/4"	11010122	11010622	11060622	10	18	36	35	44	88
2-1/2"	11010124	11010624	11060624	11	20	40	42	54	108
2-3/4"	11010125			12	22	44	51	65	130
3"	11010127			13	24	48	60	77	154
3-1/2"	11010131			16-6	32	64	79	102	204
3-3/4"	11010132			18	36	72	90	115	230
4"	11010133			20	40	80	101	130	260
4-1/2"	11010134			24	50	100	124	160	320

Note:

- Specify wire rope construction, grade, and finish if other than standard
- See weights page for weights



BLP-103

Single leg sling with alloy master link and thimble on top and thimble eye on bottom



BLP-104

Single leg sling with alloy master link and thimble on top and thimble eye & eye hook on bottom



BLP-105

Single leg sling with alloy master link and thimble on top and thimble eye & auto-locking hook on bottom

Features:

- Flemished eye splice, not a Texas tucked or turn back eye splice
- Heavy gauge stainless steel tag in accordance with ASME B30.9 and API RP2D
- Quality controlled swaging process with paint verification
- 6x19 class IWRC EIP bright wire rope supplied standard on 1/4" – 1-1/8"
- 6x37 class IWRC EIP Bright wire rope supplied standard on 1-1/4" and larger
- Proof testing available upon request
- Design factor 5 to 1

How to order:

- Specify part number and length in feet when ordering



WARNING

See wire rope sling warnings page for warnings and inspection criteria

Dia of Rope In."	Part Numbers			Min. Length ft'-in"	Standard Eye Dimensions		Rated Capacities in Short Tons		
	BLP-103	BLP-104	BLP-105		W"	L"	Choker Hitch	Vertical Hitch	Basket Hitch
1/4"	11210603	11212903	11213103	1-6	2	4	.48	.65	1.3
3/8"	11210605	11212905	11213105	2	3	6	1.1	1.4	2.8
1/2"	11210607	11212907	11213107	2-6	4	8	1.9	2.5	5.1
5/8"	11210609	11212909	11213109	3	5	10	2.9	3.9	7.8
3/4"	11210610	11212910	11213110	3-6	6	12	4.1	5.6	11.2
7/8"	11210611	11212911	11213111	4	7	14	5.6	7.6	15.2
1"	11210612	11212912	11213112	4-6	8	16	7.2	9.8	19.6
1-1/8"	11210613	11212913	11213113	5	9	18	9.1	12	24
1-1/4"	11210614	11212914	11213114	5-6	10	20	11	15	30
1-3/8"	11210615	11212915	11213115	6	11	22	13	18	36
1-1/2"	11210616	11212916	11213116	7	12	24	16	21	42
1-3/4"	11210618	11212918	11213118	8	14	28	21	28	56
2"	11210620	11212920		9	16	32	28	37	74
2-1/4"	11210622	11212922		10	18	36	35	44	88
2-1/2"	11210624	11212924		11	20	40	42	54	108
2-3/4"	11210625			12	22	44	51	65	130
3"	11210627			13	24	48	60	77	154
3-1/2"	11210631			16-6	32	64	79	102	204
3-3/4"	11210632			18	36	72	90	115	230
4"	11210633			20	40	80	101	130	260
4-1/2"	11210634			24	50	100	124	160	320

Note:

- Hook supplied standard without latch. Specify if hook requires latch
- Specify wire rope construction, grade, and finish if other than standard
- See weights page for weights



BLP-135

Single leg sling with slip-thru thimble one end with sliding choker hook in body and small eye other end

BLP-136

Single leg sling with slip-thru thimble one end with sliding choker hook in body and thimble eye other end

Features:

- Flemished eye splice, not a Texas tucked or turn back eye splice
- Heavy gauge stainless steel tag in accordance with ASME B30.9 and API RP2D
- Quality controlled swaging process with paint verification
- 6x19 class IWRC EIP bright wire rope supplied standard on 1/4" – 1-1/8"
- 6x37 class IWRC EIP Bright wire rope supplied standard on 1-1/4" and larger
- Proof testing available upon request
- Design factor 5 to 1

How to order:

- Specify part number and length in feet when ordering

⚠ WARNING

See wire rope sling warnings page for warnings and inspection criteria

Dia. of Rope	Part Numbers		Choker Capacity Short Tons	BLP-135 & BLP-136 Slip Thru Thimbles		
	BLP-135	BLP-136		Slip Thru Thimble	W inches	L inches
1/4"	11074903	11075103	.48	W-2	2-1/8"	4-1/8"
3/8"	11074905	11075105	1.1	W-2	2-1/8"	4-1/8"
1/2"	11074907	11075107	1.9	W-3	2-3/8"	4-3/8"
5/8"	11074909	11075109	2.9	W-4	3-3/8"	6-5/8"
3/4"	11074910	11075110	4.1	W-4	3-3/8"	6-5/8"
7/8"	11074911	11075111	5.6	W-5	3-3/4"	7-1/8"
1"	11074912	11075112	7.2	W-5	3-3/4"	7-1/8"
1-1/8"	11074913	11075113	9.1	W-6	4-3/8"	8-3/8"
1-1/4"	11074914	11075114	11	W-6	4-3/8"	8-3/8"
1-3/8"	11074915	11075115	13	W-7	5"	9-1/2"
1-1/2"	11074916	11075116	16	W-7	5"	9-1/2"

Note:

- Specify wire rope construction, grade, and finish if other than standard
- See weights page for weights



BLP-137

Single leg sling with
standard eye one end with
sliding choker hook in body
and small eye other end



BLP-138

Single leg sling with
standard eye one end with
sliding choker hook in body
and thimble eye other end

Features:

- Flemished eye splice, not a Texas tucked or turn back eye splice
- Heavy gauge stainless steel tag in accordance with ASME B30.9 and API RP2D
- Quality controlled swaging process with paint verification
- 6x19 class IWRC EIP bright wire rope supplied standard on 1/4" – 1-1/8"
- 6x37 class IWRC EIP Bright wire rope supplied standard on 1-1/4" and larger
- Proof testing available upon request
- Design factor 5 to 1

How to order:

- Specify part number and length in feet when ordering

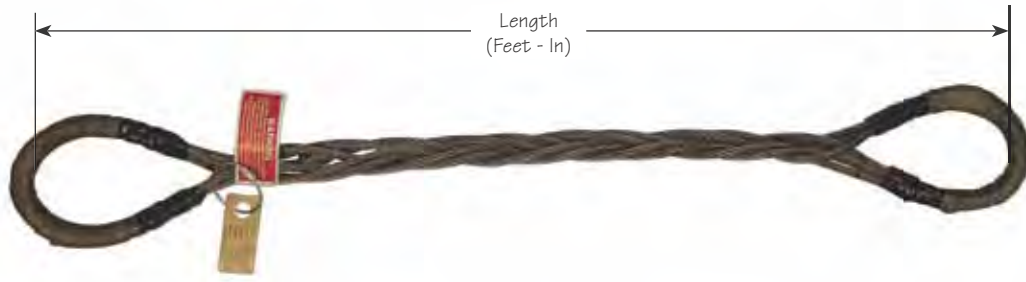
⚠ WARNING

See wire rope sling warnings page for warnings and inspection criteria

Dia. of Rope	Part Numbers		Choker Capacity Short Tons	Top Eye W" X L"	
	BLP-137	BLP-138			
1/4"	11014903	11015103	.48	2	4
3/8"	11014905	11015105	1.1	3	6
1/2"	11014907	11015107	1.9	4	8
5/8"	11014909	11015109	2.9	5	10
3/4"	11014910	11015110	4.1	6	12
7/8"	11014911	11015111	5.6	7	14
1"	11014912	11015112	7.2	8	16
1-1/8"	11014913	11015113	9.1	9	18
1-1/4"	11014914	11015114	11	10	20
1-3/8"	11014915	11015115	13	11	22
1-1/2"	11014916	11015116	16	12	24

Note:

- Specify wire rope construction, grade, and finish if other than standard
- See weights page for weights



Model: BLP-160

6-part flat braided wire rope sling with standard eyes.

Features:

- 6 part flat braid
- Standard eyes wrapped
- Heavy gauge stainless steel tag in accordance with ASME B30.9 and API RP2D
- Quality controlled swaging process with paint verification
- 7x19 class galvanized cable standard on 1/8" through 3/8"
- 6x19 class IWRC EIP bright wire rope supplied on 7/16" through 1"
- Proof testing available upon request
- Design factor 5 to 1

How to order:

- Specify part number and length in feet when ordering

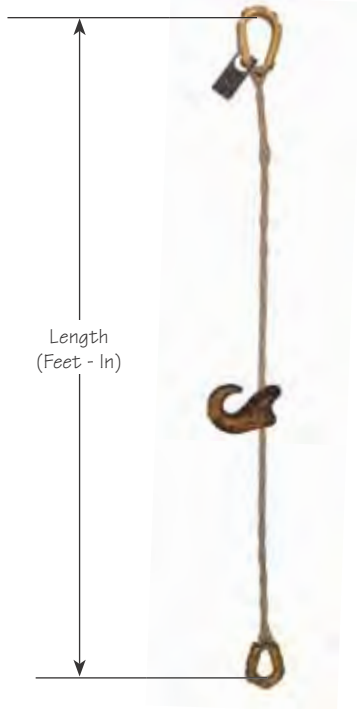
WARNING

See wire rope sling warnings page for warnings and inspection criteria

Dia. of Individual Components	Part Number	Eye Length	Min. Length	Vertical	Choke	Basket
1/8"	16010101	6"	1'-6"	.84	.73	1.6
3/16"	16010102	8"	2'	1.7	1.4	3.4
1/4"	16010103	12"	2'-6"	2.9	2.5	5.7
5/16"	16010104	12"	2'-9"	4.1	3.5	8.2
3/8"	16010105	16"	3'-6"	6	5.2	12
7/16"	16010106	18"	4'	8.6	7.5	17.2
1/2"	16010107	18"	4'-6"	11	9.8	22
9/16"	16010108	20"	5'-6"	14	12	28
5/8"	16010109	24"	6'-6"	17	15	35
3/4"	16010110	28"	7'-6"	25	22	49
7/8"	16010111	32"	8'-9"	33	29	67
1"	16010112	36"	10'-6"	43	38	87

Note:

- Specify wire rope construction, grade, and finish if other than standard
- See weights page for weights



BLP-180

8-Part braided sling with slip-thru thimble on top, with sliding choker hook and casing thimble on bottom



BLP-181

Single leg, 8-part braided sling with slip-thru thimble on top and casing thimble on bottom

Features:

- Extremely flexible and durable
- Heavy gauge stainless steel tag in accordance with ASME B30.9 and API RP2D
- Repairable if hardware passes inspection and proof testing
- 7x19 galvanized cable standard on 1/8" through 3/8"
- 6x37 class EIP IWRC bright standard on 7/16" and above
- Proof testing available upon request
- Design factor 5 to 1



Optional sliding choker hook with latch available in 1/8", 3/16", and 1/4" upon request

How to order:

- Specify part number and length in feet when ordering

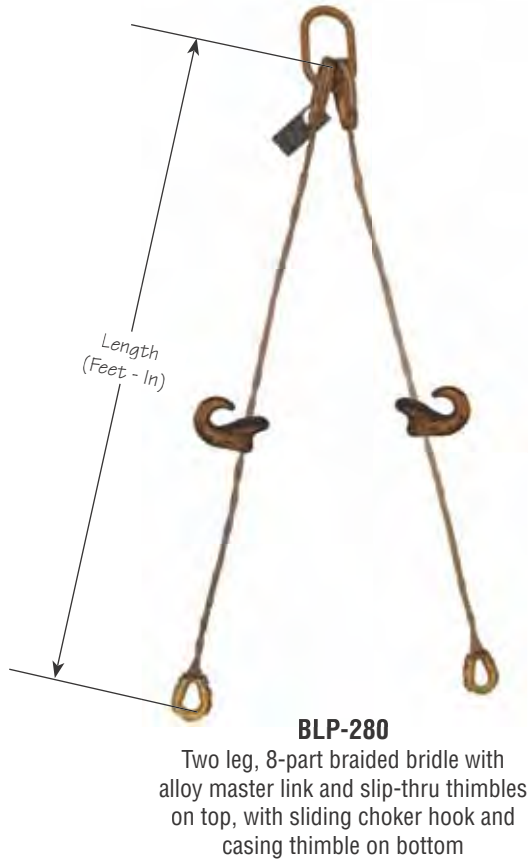
WARNING

See wire rope sling warnings page for warnings and inspection criteria

8-parts Wire Rope Components Dia.	Part Number		Approx. Body Diameter	Rated Capacities in Short Tons		
	BLP-180	BLP-181		Vertical Hitch	Choker Hitch	Vertical Basket Hitch
1/8"	18075201	18070801	5/8"	1.1	1.0	2.2
3/16"	18075202	18070802	3/4"	2.4	2.1	4.7
1/4"	18075203	18070803	1-1/8"	3.9	3.4	7.8
5/16"	18075204	18070804	1-3/8"	5.5	4.8	11.0
3/8"	18075205	18070805	1-3/4"	8.1	7.1	16.1
7/16"	18075206	18070806	2"	11.4	10.0	22.8
1/2"	18075207	18070807	2-1/4"	14.9	13.0	29.8

Note:

- Specify wire rope construction, grade, and finish if other than standard
- See weights page for weights



WIRE ROPE SLINGS

Features:

- Extremely flexible and durable
- Heavy gauge stainless steel tag in accordance with ASME B30.9 and API RP2D
- Repairable if hardware passes inspection and proof testing
- 7x19 galvanized cable standard on 1/8" through 3/8"
- 6x37 class EIP IWRC bright standard on 7/16" and above
- Proof testing available upon request
- Design factor 5 to 1



Optional sliding choker hook with latch available in 1/8", 3/16", and 1/4" upon request

How to order:

- Specify part number and length in feet when ordering

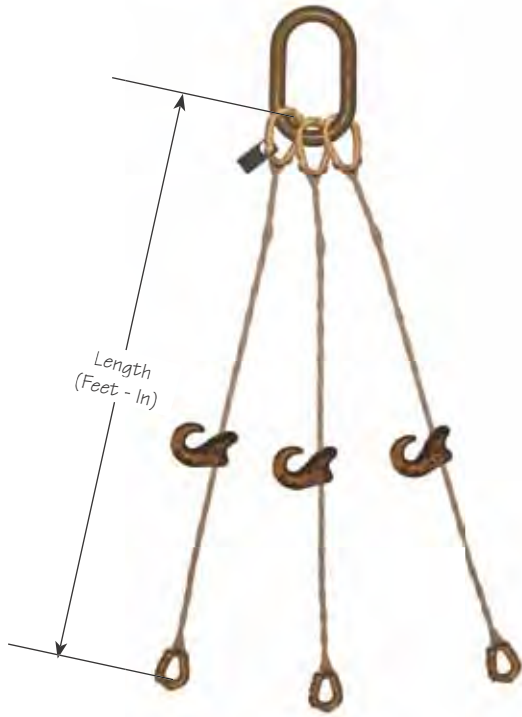
⚠ WARNING

See wire rope sling warnings page for warnings and inspection criteria

8-parts Wire Rope Components Dia.	Part Number		Approx. Body Diameter	2 Legs Vertical Rated Capacities in Short Tons			2 Legs Choked Rated Capacities in Short Tons			Master Link
	BLP-280	BLP-281		60°	45°	30°	60°	45°	30°	
1/8"	28805201	28800801	5/8"	1.9	1.6	1.1	1.7	1.4	1.0	5/8"
3/16"	28805202	28800802	3/4"	4.1	3.3	2.4	3.6	3.0	2.0	1"
1/4"	28805203	28800803	1-1/8"	6.8	5.6	3.9	5.9	4.9	3.4	1-1/2"
5/16"	28805204	28800804	1-3/8"	9.6	7.8	5.5	8.3	6.8	4.8	1-1/2"
3/8"	28805205	28800805	1-3/4"	14.0	11.5	8.1	12.2	10.0	7.0	1-1/2"
7/16"	28805206	28800806	2"	19.8	16.2	11.4	17.3	14.2	10.0	1-3/4"
1/2"	28805207	28800807	2-1/4"	25.8	21.2	14.9	22.6	18.5	13.0	2"

Note:

- Specify wire rope construction, grade, and finish if other than standard
- See weights page for weights



BLP-380

Three leg, 8-part braided with alloy master link and slip-thru thimbles on top, with sliding choker hook and casing thimble on bottom



BLP-381

Three leg, 8-part braided with alloy master link and slip-thru thimble on top and casing thimble on bottom

Features:

- Extremely flexible and durable
- Heavy gauge stainless steel tag in accordance with ASME B30.9 and API RP2D
- Repairable if hardware passes inspection and proof testing
- 7x19 galvanized cable standard on 1/8" through 3/8"
- 6x37 class EIP IWRC bright standard on 7/16" and above
- Proof testing available upon request
- Design factor 5 to 1



Optional sliding choker hook with latch available in 1/8", 3/16", and 1/4" upon request

How to order:

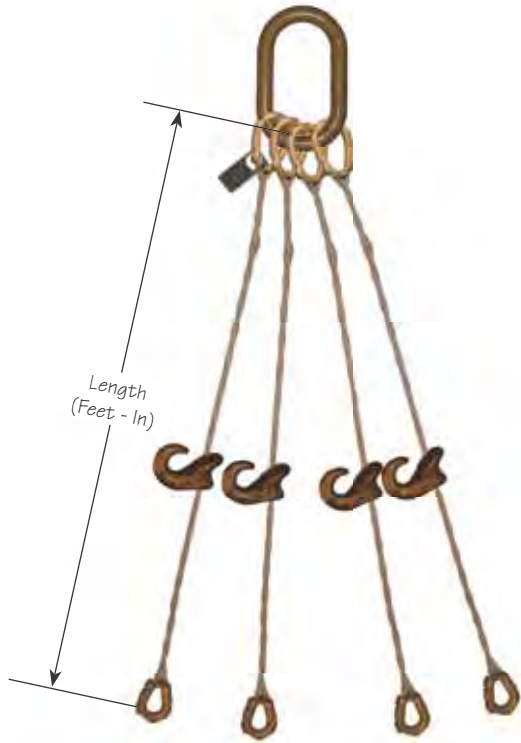
- Specify part number and length in feet when ordering

⚠ WARNING
See wire rope sling warnings page for warnings and inspection criteria

8-parts Wire Rope Components Dia.	Part Number		Approx. Body Diameter	3 Legs Vertical Rated Capacities in Short Tons			3 Legs Choked Rated Capacities in Short Tons			Master Link
	BLP-380	BLP-381		60°	45°	30°	60°	45°	30°	
1/8"	38805201	38800801	5/8"	2.9	2.4	1.7	2.55	2.1	1.5	1"
3/16"	38805202	38800802	3/4"	6.1	5.0	3.5	5.35	4.4	3.1	1-1/2"
1/4"	38805203	38800803	1-1/8"	10.2	8.4	5.0	8.91	7.3	5.2	1-1/2"
5/16"	38805204	38800804	1-3/8"	14.3	11.7	8.2	12.48	10.2	7.2	2"
3/8"	38805205	38800805	1-3/4"	21.0	17.2	12.1	18.33	15.0	10.6	2"
7/16"	38805206	38800806	2"	29.7	24.3	17.1	25.97	21.3	15.0	2-1/4"
1/2"	38805207	38800807	2-1/4"	38.7	31.7	22.3	33.86	27.8	19.6	2-1/4"

Note:

- Specify wire rope construction, grade, and finish if other than standard
- Rated capacity based on all three legs carrying the load equally
- See weights page for weights



BLP-480

Four leg, 8-part braided sling with alloy master link and slip-thru thimbles on top, with sliding choker hook and casing thimble on bottom



BLP-481

Four leg, 8-part braided sling with alloy master link and slip-thru thimble on top and casing thimble on bottom

Features:

- Extremely flexible and durable
- Heavy gauge stainless steel tag in accordance with ASME B30.9 and API RP2D
- Repairable if hardware passes inspection and proof testing
- 7x19 galvanized cable standard on 1/8" through 3/8"
- 6x37 class EIP IWRC bright standard on 7/16" and above
- Proof testing available upon request
- Design factor 5 to 1



Optional sliding choker hook with latch available in 1/8", 3/16", and 1/4" upon request

WARNING

See wire rope sling warnings page for warnings and inspection criteria

How to order:

- Specify part number and length in feet when ordering

8-parts Wire Rope Components Dia.	Part Number		Approx. Body Diameter	4 Legs Vertical Rated Capacities in Short Tons			4 Legs Choked Rated Capacities in Short Tons			Master Link
	BLP-480	BLP-481		60°	45°	30°	60°	45°	30°	
1/8"	48805201	48800801	5/8"	3.9	3.2	2.2	3.4	2.8	1.96	1-1/2"
3/16"	48805202	48800802	3/4"	8.2	6.7	4.7	7.1	5.8	4.12	2"
1/4"	48805203	48800803	1-1/8"	13.6	11.1	7.8	11.9	9.7	6.86	2-1/4"
5/16"	48805204	48800804	1-3/8"	19.0	15.6	11.0	16.6	13.6	9.60	2-1/4"
3/8"	48805205	48800805	1-3/4"	27.9	22.9	16.1	24.4	20.0	14.11	2-1/4"
7/16"	48805206	48800806	2"	39.6	32.4	22.9	34.6	28.4	19.99	2-3/4"
1/2"	48805207	48800807	2-1/4"	51.6	42.3	29.8	45.2	37.0	26.07	2-3/4"

Note:

- Specify wire rope construction, grade, and finish if other than standard
- Rated capacity based on all four legs carrying the load equally
- See weights page for weights



BLP-200

Two leg bridle sling with alloy master link and thimbles on top, with thimbles and eye hooks on bottom



BLP-201

Two leg bridle sling with alloy master link and thimbles on top, with thimbles only on bottom

Features:

- Flemished eye splice, not a Texas tucked or turn back eye splice
- Heavy gauge stainless steel tag in accordance with ASME B30.9 and API RP2D
- Quality controlled swaging process with paint verification
- 6x19 class IWRC EIP bright wire rope supplied standard on 1/4" – 1-1/8"
- 6x37 class IWRC EIP bright wire rope supplied standard on 1-1/4" and larger
- Proof testing available upon request
- Design factor 5 to 1

How to order:

- Specify part number and length in feet when ordering

WARNING

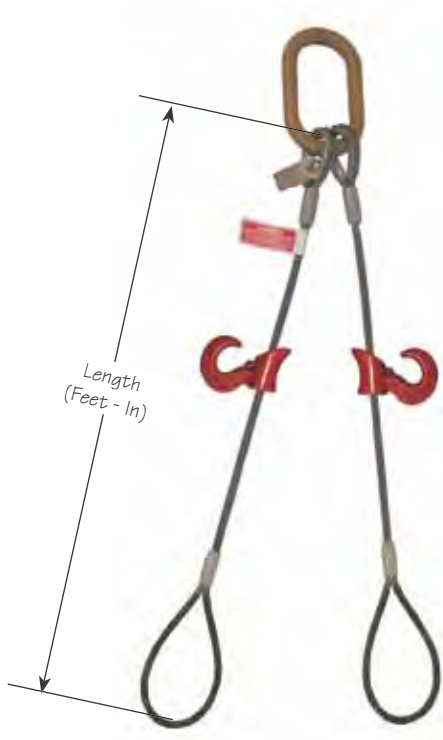
See wire rope sling warnings page for warnings and inspection criteria

Wire Rope Dia.	Part Number		Min. Length Ft - In	Capacities in Short Tons			Standard Hardware	
	BLP-200	BLP-201		Capacities from the Horizontal			Alloy Master Link	Eye Hooks
				60°	45°	30°		
1/4"	21212903	21210603	1-3	1.1	.92	.65	1/2"	3/4 ton -S-320N-C
3/8"	21212905	21210605	1-8	2.5	2.0	1.4	3/4"	1.5 ton S-320N-C
1/2"	21212907	21210607	2-0	4.4	3.6	2.5	1"	3 ton S-320N-C
5/8"	21212909	21210609	2-4	6.8	5.5	3.9	1-1/4"	5 ton S-320N-C
3/4"	21212910	21210610	2-9	9.7	7.9	5.6	1-1/4"	7 ton S-320N-A
7/8"	21212911	21210611	3-3	13	11	7.6	1-1/4"	7.5 ton S-320N-C
1"	21212912	21210612	3-6	17	14	9.8	1-1/2"	10 ton S-320N-C
1-1/8"	21212913	21210613	4-0	21	17	12	1-3/4"	15 ton S-320N-A
1-1/4"	21212914	21210614	4-6	26	21	15	1-3/4"	15 ton S-320N-A
1-3/8"	21212915	21210615	5-0	31	25	18	2"	20 ton S-320-C
1-1/2"	21212916	21210616	5-6	37	30	21	2"	22 ton S-320N-A
1-3/4"	21212918	21210618	6-6	49	40	28	2-1/2"	30 ton S-320-A
2"	21212920	21210620	8-0	63	52	37	2-3/4"	37 ton S-320-A

Note:

- Hooks supplied standard without latches. Specify if hooks require latches
- Specify wire rope construction, grade, and finish if other than standard
- Specify master link and hooks size if other than standard
- See weights page for weights

WIRE ROPE SLINGS



BLP-237

Two leg bridle sling with alloy master link and thimbles on top and sliding choker hook in body with standard eyes on bottom



BLP-202

Two leg bridle sling with alloy master link and thimbles on top and sliding choker hook in body with thimble eyes on bottom

Features:

- Flemished eye splice, not a Texas tucked or turn back eye splice
- Heavy gauge stainless steel tag in accordance with ASME B30.9 and API RP2D
- Quality controlled swaging process with paint verification
- 6x19 class IWRC EIP bright wire rope supplied standard
- Proof testing available upon request
- Design factor 5 to 1

How to order:

- Specify part number and length in feet when ordering

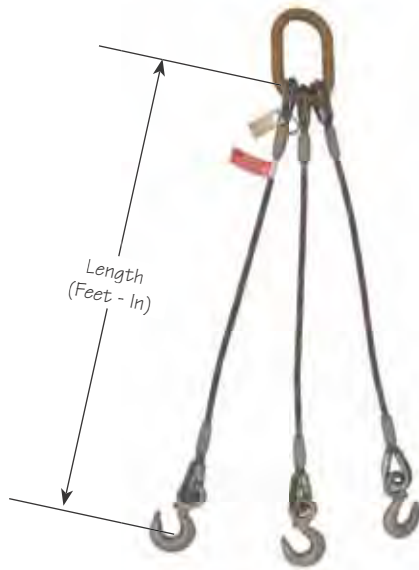
⚠ WARNING

See wire rope sling warnings page for warnings and inspection criteria

Wire Rope Dia.	Part Number		Min. Length Ft - In	Capacities in Short Tons					
	BLP-237	BLP-202		Capacities from the Horizontal Vertical Hitch			Capacities from the Horizontal Choker Hitch		
				60°	45°	30°	60°	45°	30°
1/4"	21215003	21215103	1-3	1.1	.92	.65	.83	.68	.48
3/8"	21215005	21215105	1-8	2.5	2.0	1.4	1.9	1.5	1.1
1/2"	21215007	21215107	2-0	4.4	3.6	2.5	3.3	2.6	1.9
5/8"	21215009	21215109	2-4	6.8	5.5	3.9	5.0	4.1	2.9
3/4"	21215010	21215110	2-9	9.7	7.9	5.6	7.0	5.8	4.1
7/8"	21215011	21215111	3-3	13	11	7.6	9.6	7.9	5.6
1"	21215012	21215112	3-6	17	14	9.8	12.4	10.2	7.2

Note:

- Specify wire rope construction, grade, and finish if other than standard
- Specify master link size if other than standard
- See weights page for weights



BLP-300

Three leg bridle with alloy master link and thimbles on top, with thimbles and eye hooks on bottom



BLP-301

Three leg bridle with alloy master link and thimbles on top, with thimbles only on bottom

Features:

- Flemished eye splice, not a Texas tucked or turn back eye splice
- Heavy gauge stainless steel tag in accordance with ASME B30.9 and API RP2D
- Quality controlled swaging process with paint verification
- 6x19 class IWRC EIP bright wire rope supplied standard on 1/4" – 1-1/8"
- 6x37 class IWRC EIP bright wire rope supplied standard on 1-1/4" and larger
- Proof testing available upon request
- Design factor 5 to 1

How to order:

- Specify part number and length in feet when ordering



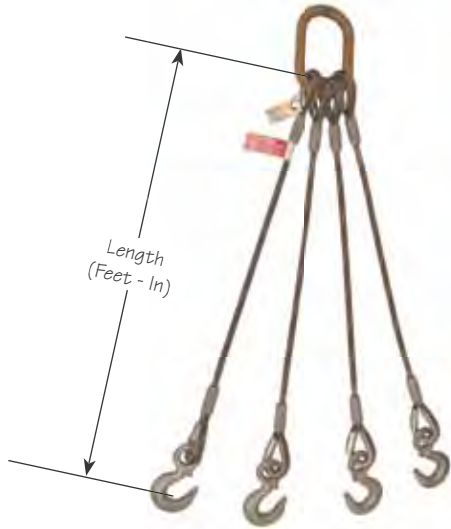
WARNING

See wire rope sling warnings page for warnings and inspection criteria

Wire Rope Dia.	Part Numbers		Min. Length Ft - In	Capacities in Short Tons			Standard Hardware	
	BLP-300	BLP-301		Capacities from the Horizontal			Alloy Master Link	Eye Hooks
				60°	45°	30°		
1/4"	31212903	31210603	1-3	1.7	1.4	.97	5/8"	3/4 ton -S-320N-C
3/8"	31212905	31210605	1-8	3.7	3.0	2.2	7/8"	1.5 ton S-320N-C
1/2"	31212907	31210607	2-0	6.6	5.4	3.8	1-1/4"	3 ton S-320N-C
5/8"	31212909	31210609	2-4	10	8.3	5.9	1-1/4"	5 ton S-320N-C
3/4"	31212910	31210610	2-9	15	12	8.4	1-1/2"	7 ton S-320N-A
7/8"	31212911	31210611	3-3	20	16	11	1-1/2"	7.5 ton S-320N-C
1"	31212912	31210612	3-6	26	21	15	1-3/4"	10 ton S-320N-C
1-1/8"	31212913	31210613	4-0	31	26	18	2"	15 ton S-320N-A
1-1/4"	31212914	31210614	4-6	38	31	22	2"	15 ton S-320N-A
1-3/8"	31212915	31210615	5-0	46	38	27	2-1/4"	20 ton S-320-C
1-1/2"	31212916	31210616	5-6	55	45	32	2-1/2"	22 ton S-320N-A
1-3/4"	31212918	31210618	6-6	74	60	42	-	30 ton S-320-A
2"	31212920	31210620	8-0	95	78	55	-	37 ton S-320-A

Note:

- Hooks supplied standard without latches. Specify if hooks require latches
- Specify master link size on 1-3/4" and larger
- Specify wire rope construction, grade, and finish if other than standard
- Specify master link and hook size if other than standard
- Rated capacity based on all three legs carrying the load equally
- See weights page for weights



BLP-400

Four leg bridle slings with alloy master link and thimbles on top, with thimbles and eye hooks on bottom



BLP-401

Four leg bridle slings with alloy master link and thimbles on top, with thimbles only on bottom

Features:

- Flemished eye splice, not a Texas tucked or turn back eye splice
- Heavy gauge stainless steel tag in accordance with ASME B30.9 and API RP2D
- Quality controlled swaging process with paint verification
- 6x19 class IWRC EIP bright wire rope supplied standard on 1/4" – 1-1/8"
- 6x37 class IWRC EIP bright wire rope supplied standard on 1-1/4" and larger
- Proof testing available upon request
- Design factor 5 to 1

How to order:

- Specify part number and length in feet when ordering

WARNING

See wire rope sling warnings page for warnings and inspection criteria

Wire Rope Dia.	Part Number		Min. Length Ft - In	Capacities in Short Tons			Standard Hardware	
	BLP-400	BLP-401		Capacities from the Horizontal			Alloy Master Link	Eye Hooks
				60°	45°	30°		
1/4"	41212903	41210603	1-3	2.2	1.8	1.3	3/4"	3/4 ton -S-320N-C
3/8"	41212905	41210605	1-8	5.0	4.1	2.9	1"	1.5 ton S-320N-C
1/2"	41212907	41210607	2-0	8.8	7.1	5.1	1-1/4"	3 ton S-320N-C
5/8"	41212909	41210609	2-4	14	11	7.8	1-1/4"	5 ton S-320N-C
3/4"	41212910	41210610	2-9	19	16	11	1-1/2"	7 ton S-320N-A
7/8"	41212911	41210611	3-3	26	21	15	1-3/4"	7.5 ton S-320N-C
1"	41212912	41210612	3-6	34	28	20	2"	10 ton S-320N-C
1-1/8"	41212913	41210613	4-0	42	34	24	2-1/4"	15 ton S-320N-A
1-1/4"	41212914	41210614	4-6	51	42	30	2-1/2"	15 ton S-320N-A
1-3/8"	41212915	41210615	5-0	62	50	36	-	20 ton S-320-C
1-1/2"	41212916	41210616	5-6	73	60	42	-	22 ton S-320N-A
1-3/4"	41212918	41210618	6-6	98	80	57	-	30 ton S-320-A
2"	41212920	41210620	8-0	127	104	73	-	37 ton S-320-A

Note:

- Hooks supplied standard without latches. Specify if hooks require latches
- Specify master link size on 1-3/8" and larger
- Specify wire rope construction, grade, and finish if other than standard
- Specify master link and hook size if other than standard
- Notify BLP at time of purchase if used on a personnel lifting basket
- Rated capacity based on all four legs carrying the load equally
- See weights page for weights



BLP-203

Two leg bridle with alloy master link and thimbles on top, with thimbles and sorting hooks on bottom

BLP-303

Three leg bridle with alloy master link and thimbles on top, with thimbles and sorting hooks on bottom

BLP-403

Four leg bridle with alloy master link and thimbles on top, with thimbles and sorting hooks on bottom

Features:

- Flemished eye splice, not a Texas tucked or turn back eye splice
- Heavy gauge stainless steel tag in accordance with ASME B30.9 and API RP2D
- Quality controlled swaging process with paint verification
- 6x19 class IWRC EIP bright wire rope supplied standard
- Proof testing available upon request
- Design factor 5 to 1

How to order:

- Specify part number and length in feet when ordering

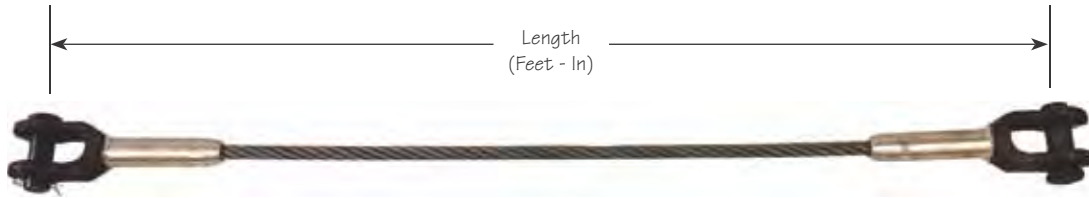
WARNING

See wire rope sling warnings page for warnings and inspection criteria

Wire Rope Dia.	Part Number			Min. Length Ft - In	Capacities in Short Tons			Standard Hardware
	BLP-203	BLP-303	BLP-403		Capacities from the Horizontal			
					BLP-203	BLP-303	BLP-403	Sorting Hooks
1/2"	21213307	31213307	41213307	2-0	60°	60°	60°	2 ton A-378
5/8"	21213309	31213309	41213309	2-4	3.4	5.1	6.9	2 ton A-378

Note:

- Specify wire rope construction, grade, and finish if other than standard
- Rated capacity based on all legs carrying the load equally
- See weights page for weights



BLP-500
Single leg socket line with
open swage socket each
end, pins parallel



BLP-501
Single leg socket line with
open swage socket each
end, pins at right angles

Features:

- Heavy gauge stainless steel tag in accordance with ASME B30.9 and API RP2D
- Proof tested to 2X Rated Capacity
- 6x19 class IWRC EIP bright wire rope supplied standard
- 100% termination efficiency
- Design factor 5 to 1

How to order:

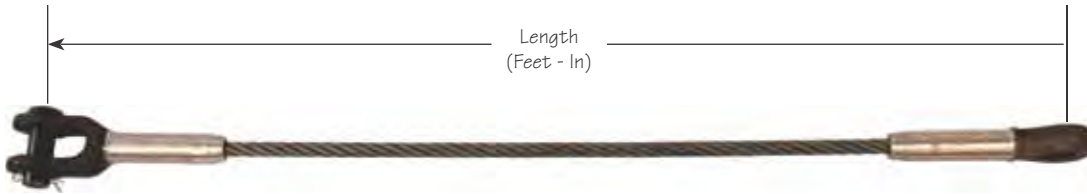
- Specify part number and length in feet when ordering

WARNING
See wire rope sling warnings page
for warnings and inspection criteria

Dia. of Rope	BLP-500	BLP-501	Min. Sling Length ft.-in.	EIPS Rated Capacity in Short Tons	EEIP Rated Capacity in Short Tons
3/8"	11151505	11202005	1-0	1.5	1.7
1/2"	11151507	11202007	1-8	2.7	2.9
5/8"	11151509	11202009	2-0	4.1	4.5
3/4"	11151510	11202010	2-5	5.9	6.5
7/8"	11151511	11202011	2-10	8.0	8.8
1"	11151512	11202012	3-2	10	11.4
1-1/8"	11151513	11202013	3-7	13	14.3
1-1/4"	11151514	11202014	4-0	16	17.6
1-3/8"	11151515	11202015	4-5	19	20.2
1-1/2"	11151516	11202016	4-9	23	25
1-3/4"	11151518	11202018	5-5	31	33.8
2"	11151520	11202020	6-4	40	43.4

Note:

- Specify wire rope construction, grade, and finish if other than standard
- See weights page for weights



BLP-502

Single leg socket line with open swage socket one end and closed swage socket other end, pins parallel



BLP-503

Single leg socket line with open swage socket one end and closed swage socket other end, pins at right angles

Features:

- Heavy gauge stainless steel tag in accordance with ASME B30.9 and API RP2D
- Proof tested to 2X Rated Capacity
- 6x19 class IWRC EIP bright wire rope supplied standard
- 100% termination efficiency
- Design factor 5 to 1

How to order:

- Specify part number and length in feet when ordering

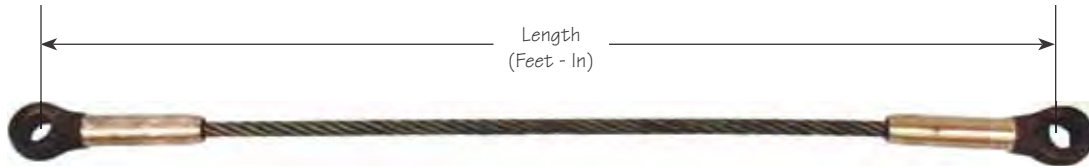
WARNING

See wire rope sling warnings page for warnings and inspection criteria

Dia. of Rope	BLP-502	BLP-503	Min. Sling Length ft.-in.	EIPS Rated Capacity in Short Tons	EEIP Rated Capacity in Short Tons
3/8"	11151405	11201905	1-0	1.5	1.7
1/2"	11151407	11201907	1-8	2.7	2.9
5/8"	11151409	11201909	2-0	4.1	4.5
3/4"	11151410	11201910	2-5	5.9	6.5
7/8"	11151411	11201911	2-10	8.0	8.8
1"	11151412	11201912	3-2	10	11.4
1-1/8"	11151413	11201913	3-7	13	14.3
1-1/4"	11151414	11201914	4-0	16	17.6
1-3/8"	11151415	11201915	4-5	19	20.2
1-1/2"	11151416	11201916	4-9	23	25
1-3/4"	11151418	11201918	5-5	31	33.8
2"	11151420	11201920	6-4	40	43.4

Note:

- Specify wire rope construction, grade, and finish if other than standard
- See weights page for weights



BLP-504
Socket line with closed
swage socket each end, pins
parallel



BLP-505
Socket line with closed
swage socket each end, pins
at right angles

Features:

- Heavy gauge stainless steel tag in accordance with ASME B30.9 and API RP2D
- Proof tested to 2X Rated Capacity
- 6x19 class IWRC EIP bright wire rope supplied standard
- 100% termination efficiency
- Design factor 5 to 1

How to order:

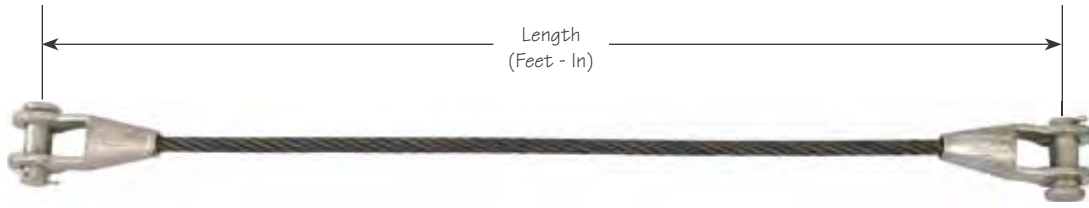
- Specify part number and length in feet when ordering

WARNING
See wire rope sling warnings page
for warnings and inspection criteria

Dia. of Rope	BLP-504	BLP-505	Min. Sling Length ft.-in.	EIPS Rated Capacity in Short Tons	EEIP Rated Capacity in Short Tons
3/8"	11141405	11191905	1-0	1.5	1.7
1/2"	11141407	11191907	1-8	2.7	2.9
5/8"	11141409	11191909	2-0	4.1	4.5
3/4"	11141410	11191910	2-5	5.9	6.5
7/8"	11141411	11191911	2-10	8.0	8.8
1"	11141412	11191912	3-2	10	11.4
1-1/8"	11141413	11191913	3-7	13	14.3
1-1/4"	11141414	11191914	4-0	16	17.6
1-3/8"	11141415	11191915	4-5	19	20.2
1-1/2"	11141416	11191916	4-9	23	25
1-3/4"	11141418	11191918	5-5	31	33.8
2"	11141420	11191920	6-4	40	43.4

Note:

- Specify wire rope construction, grade, and finish if other than standard
- See weights page for weights



BLP-600
Socket line with open
spelter socket each end,
pins parallel



BLP-601
Socket line with open
spelter socket each end,
pins at right angles

Features:

- Heavy gauge stainless steel tag in accordance with ASME B30.9 and API RP2D
- Proof tested to 2X Rated Capacity
- Spelter sockets attached with WIRELOCK®
- 6x19 Class IWRC EIP bright wire rope supplied standard up to 2"
- 6x36 Class IWRC EIP bright wire rope supplied standard on 2-1/2" and larger
- 100% termination efficiency
- Design factor 5 to 1

How to order:

- Specify part number and length in feet when ordering

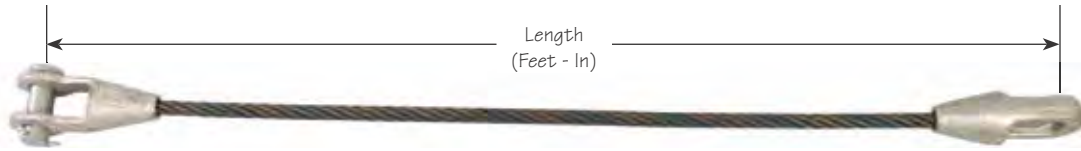
⚠ WARNING

See wire rope sling warnings page
for warnings and inspection criteria

Dia. of Rope	BLP-600	BLP-601	Min. Sling Length ft.-in.	EIPS Rated Capacity in Short Tons	EEIP Rated Capacity in Short Tons
3/8"	11131305	11181805	1-0	1.5	1.7
1/2"	11131307	11181807	1-3	2.7	2.9
5/8"	11131309	11181809	1-6	4.1	4.5
3/4"	11131310	11181810	1-9	5.9	6.5
7/8"	11131311	11181811	2-0	8.0	8.8
1"	11131312	11181812	2-6	10	11.4
1-1/8"	11131313	11181813	2-9	13	14.3
1-1/4"	11131314	11181814	3-0	16	17.6
1-3/8"	11131315	11181815	3-0	19	20.2
1-1/2"	11131316	11181816	3-3	23	25
1-3/4"	11131318	11181818	4-3	31	33.8
2"	11131320	11181820	4-9	40	43.4
2-1/2"	11131324	11181824	5-9	60	66
2-3/4"	11131325	11181825	6-2	72	79
3"	11131327	11181827	6-6	85	94
3-1/2"	11131331	11181831	7-6	113	124

Note:

- Specify wire rope construction, grade, and finish if other than standard
- See weights page for weights



BLP-602

Socket line with open spelter socket one end and closed spelter socket other end, pins parallel



BLP-603

Socket line with open spelter socket one end and closed spelter socket other end, pins at right angles

Features:

- Heavy gauge stainless steel tag in accordance with ASME B30.9 and API RP2D
- Proof tested to 2X Rated Capacity
- Spelter sockets attached with WIRELOCK®
- 6x19 Class IWRC EIP bright wire rope supplied standard up to 2"
- 6x36 Class IWRC EIP bright wire rope supplied standard on 2-1/2" and larger
- 100% termination efficiency
- Design factor 5 to 1

How to order:

- Specify part number and length in feet when ordering

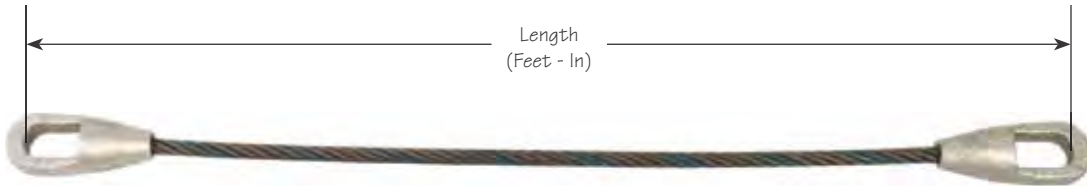
⚠ WARNING

See wire rope sling warnings page for warnings and inspection criteria

Dia. of Rope	BLP-602	BLP-603	Min. Sling Length ft.-in.	EIPS Rated Capacity in Short Tons	EEIP Rated Capacity in Short Tons
3/8"	11131205	11181705	1-0	1.5	1.7
1/2"	11131207	11181707	1-3	2.7	2.9
5/8"	11131209	11181709	1-6	4.1	4.5
3/4"	11131210	11181710	1-9	5.9	6.5
7/8"	11131211	11181711	2-0	8.0	8.8
1"	11131212	11181712	2-6	10	11.4
1-1/8"	11131213	11181713	2-9	13	14.3
1-1/4"	11131214	11181714	3-0	16	17.6
1-3/8"	11131215	11181715	3-0	19	20.2
1-1/2"	11131216	11181716	3-3	23	25
1-3/4"	11131218	11181718	4-3	31	33.8
2"	11131220	11181720	4-9	40	43.4
2-1/2"	11131224	11181724	5-9	60	66
2-3/4"	11131225	11181725	6-2	72	79
3"	11131227	11181727	6-6	85	94
3-1/2"	11131231	11181731	7-6	113	124

Note:

- Specify wire rope construction, grade, and finish if other than standard
- See weights page for weights



BLP-604

Socket line with closed spelter
socket each end, pins parallel



BLP-605

Socket line with closed spelter
socket each end, pins at right
angles

Features:

- Heavy gauge stainless steel tag in accordance with ASME B30.9 and API RP2D
- Proof tested to 2X Rated Capacity
- Spelter sockets attached with WIRELOCK®
- 6x19 Class IWRC EIP bright wire rope supplied standard up to 2"
- 6x36 Class IWRC EIP bright wire rope supplied standard on 2-1/2" and larger
- 100% termination efficiency
- Design factor 5 to 1

How to order:

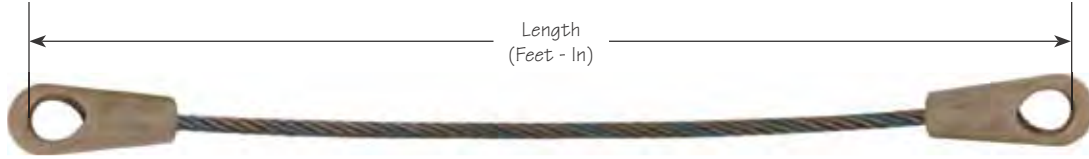
- Specify part number and length in feet when ordering

WARNING
See wire rope sling warnings page
for warnings and inspection criteria

Dia. of Rope	BLP-604	BLP-605	Min. Sling Length ft.-in.	EIPS Rated Capacity in Short Tons	EEIP Rated Capacity in Short Tons
3/8"	11121205	11171705	1-0	1.5	1.7
1/2"	11121207	11171707	1-3	2.7	2.9
5/8"	11121209	11171709	1-6	4.1	4.5
3/4"	11121210	11171710	1-9	5.9	6.5
7/8"	11121211	11171711	2-0	8.0	8.8
1"	11121212	11171712	2-6	10	11.4
1-1/8"	11121213	11171713	2-9	13	14.3
1-1/4"	11121214	11171714	3-0	16	17.6
1-3/8"	11121215	11171715	3-0	19	20.2
1-1/2"	11121216	11171716	3-3	23	25
1-3/4"	11121218	11171718	4-3	31	33.8
2"	11121220	11171720	4-9	40	43.4
2-1/2"	11121224	11171724	5-9	60	66
2-3/4"	11121225	11171725	6-2	72	79
3"	11121227	11171727	6-6	85	94
3-1/2"	11121231	11171731	7-6	113	124

Note:

- Specify wire rope construction, grade, and finish if other than standard
- See weights page for weights



BLP-606

Socket line with mooring spelter
socket each end, bails parallel



BLP-607

Socket line with mooring spelter
socket each end, bails at right
angles

Features:

- Heavy gauge stainless steel tag in accordance with ASME B30.9 and API RP2D
- Proof tested to 2X Rated Capacity
- Mooring sockets attached with WIRELOCK®
- 6x19 Class IWRC EIP bright wire rope supplied standard up to 2"
- 6x36 Class IWRC EIP bright wire rope supplied standard on 2-1/2" and larger
- 100% termination efficiency
- Design factor 5 to 1

How to order:

- Specify part number and length in feet when ordering

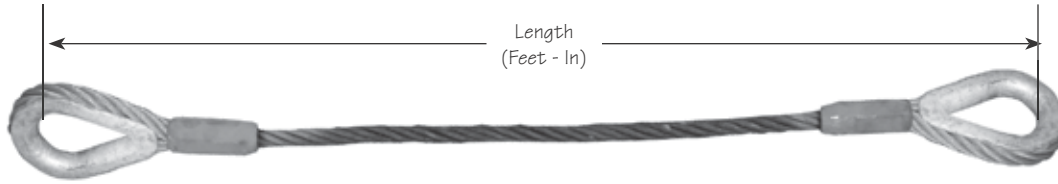


See wire rope sling warnings page
for warnings and inspection criteria

Dia. of Rope	BLP-606	BLP-607	Min. Sling Length ft.-in.	EIPS Rated Capacity in Short Tons	EEIP Rated Capacity in Short Tons
2"	11111120	11161620	4-4	40	43.4
2-1/4"	11111122	11161622	4-7	49.4	56.4
2-1/2"	11111124	11161624	5-5	60.4	66.4
2-3/4"	11111125	11161625	5-8	72.2	79.4
3"	11111127	11161627	6-5	85	93.6
3-1/2"	11111131	11161631	7-5	112.8	124.2

Note:

- Specify wire rope construction, grade, and finish if other than standard
- See weights page for weights



BLP-608
Single leg sling with hawser
thimbles each end

Features:

- Flemished eye splice, not a tucked or returned eye splice
- Heavy gauge stainless steel tag in accordance with ASME B30.9 and API RP2D
- Quality controlled swaging process with paint verification
- 6x19 Class IWRC EIP bright wire rope supplied standard up to 2"
- 6x36 Class IWRC EIP bright wire rope supplied standard on 2-1/2" and larger
- Hot galvanized cast alloy steel Hawser thimble each end
- Proof testing available on request
- Design factor 5 to 1

How to order:

- Specify part number and length in feet when ordering

WARNING
See wire rope sling warnings page
for warnings and inspection criteria

Dia. of Rope	Part Number	Min. Sling Length ft.-in.	Rated Capacity Vertical (short tons)
5/8"	11101009	3	3.9
3/4"	1110 1010	3-6	5.6
7/8"	11101011	4	7.6
1"	11101012	4-6	9.8
1-1/8"	11101013	5	12
1-1/4"	11101014	5-6	15
1-3/8"	11101015	6	18
1-1/2"	11101016	7	21
1-3/4"	11101018	8	28
2"	11101020	9	37
2-1/4"	11101022	10	44
2-1/2"	11101024	11	54
2-3/4"	11101025	12	65
3"	11101027	13	77

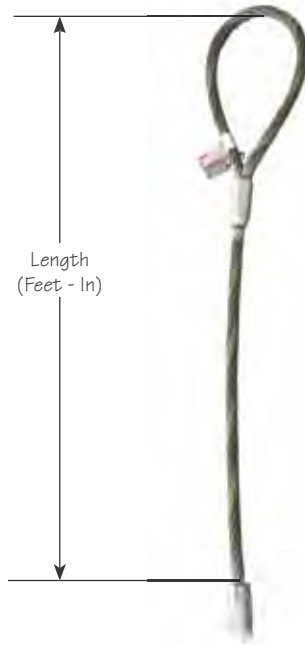
Note:

- Specify wire rope type, finish, and construction if other than standard
- See weights page for weights

WIRE ROPE SLINGS



TC
Tea cup carrier for handling box culverts



Length
(Feet - In)

BLP-106

Single leg sling with standard eye top end and standard swage button bottom end



Length
(Feet - In)

BLP-207

Two leg bridle with alloy master link and thimbles top end and standard swage buttons bottom end

Features:

- Flemished eye splice, not a Texas tucked or turn back eye splice
- Heavy gauge stainless steel tag in accordance with ASME B30.9 and API RP2D
- Quality controlled swaging process with paint verification
- 6x19 class IWRC EIP bright wire rope supplied standard
- Proof testing available upon request
- Design factor 5 to 1

How to order:

- Specify part number and length in feet when ordering

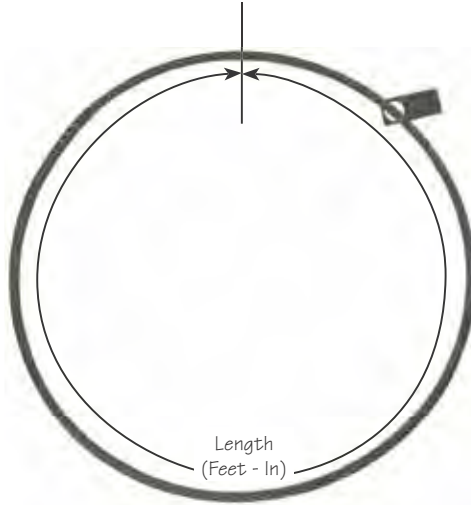
WARNING

See wire rope sling warnings page for warnings and inspection criteria

Dia of Rope	Part Numbers			Min. Sling Length	Loop Dim. Inches		Rated Capacities in Tons	
	Tea Cup	BLP-106	BLP-207		L	W	Single Leg 90°	Two Legs 60°
5/8"	TC-1	11013909	21213909	3'	5	10	3.9	6.7
3/4"	TC-2	11013910	21213910	3'-6"	6	12	5.6	9.6
7/8"	TC-2	11013911	21213911	4'	7	14	7.6	13.1
1"	TC-3	11013912	21213912	4'-6"	8	16	9.8	16.97
1-1/8"	TC-3	11013913	21213913	5'	9	18	12	20.7
1-1/4"	TC-4	11013914	21213914	5'-6"	10	20	15	25.9
1-3/8"	TC-5	11013915	21213915	6'	11	22	18	31.1
1-1/2"	TC-5	11013916	21213916	7'	12	24	21	36.3

Note:

- Specify wire rope construction, grade, and finish if other than standard
- See weights page for weights



BLP-011
Strand laid grommet

Features:

- Strand laid hand tucked splice
- Heavy gauge stainless steel tag in accordance with ASME B30.9 & API RP2D
- 6x19 class IWRC EIP bright wire rope supplied standard
- Basket hitch capacity based on pin diameter of 5 times the diameter of the wire rope
- Proof testing available on request
- Design factor of 5 to 1

How to order:

- Specify part number and length in feet when ordering

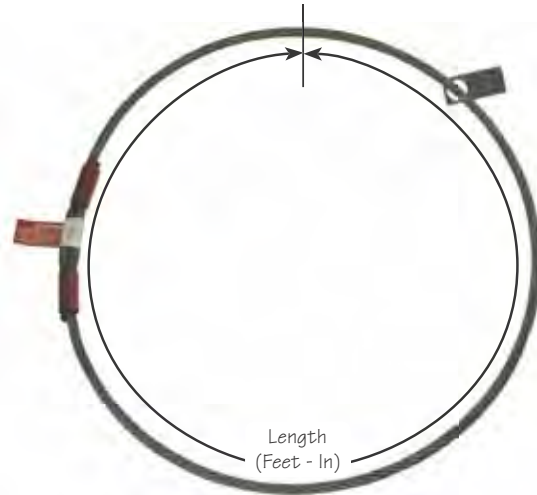
WARNING
See wire rope sling warnings page for warnings and inspection criteria

Dia. of Rope	Part Number	Rated Capacities in Short Tons		
		Vertical	Choker	Vertical Basket
3/8"	01606005	2.4	1.6	4.7
1/2"	01606007	4.1	2.9	8.3
5/8"	01606009	6.4	4.5	12.9
3/4"	01606010	9.2	6.4	18.3
7/8"	01606011	12.4	8.7	24.8
1"	01606012	16.0	11.2	32.1

Note:

- Specify wire rope construction, grade, and finish if other than standard
- See weights page for weights

WIRE ROPE SLINGS



BLP-012
Turnback sleeve grommet

Features:

- Turnback termination
- Heavy gauge stainless steel tag in accordance with ASME B30.9 & API RP2D
- 6x19 class IWRC EIP bright wire rope supplied standard
- Basket hitch capacity based on pin diameter of 5 times the diameter of the wire rope
- Proof testing available on request
- Design factor of 5 to 1

How to order:

- Specify part number and length in feet when ordering

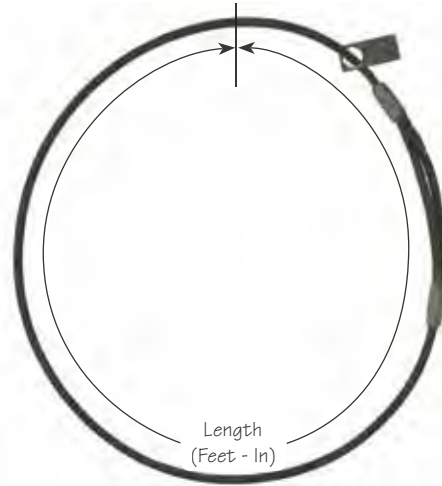
⚠ WARNING

See wire rope sling warnings page for warnings and inspection criteria

Dia. of Rope	Part Number BLP-012	Min. Sling Length ft-in.	Rated Capacities in Short Tons		
			Vertical	Choker	Vertical Basket
3/8"	01616105	2-8	2.4	1.6	4.7
1/2"	01616107	3-4	4.1	2.9	8.3
5/8"	01616109	4-0	6.4	4.5	12.9
3/4"	01616110	5-0	9.2	6.4	18.3
7/8"	01616111	5-8	12.4	8.7	24.8
1"	01616112	6-6	16.1	11.3	32.3

Note:

- Specify wire rope construction, grade, and finish if other than standard
- See weights page for weights



BLP-013
Mechanically flemished grommet

Features:

- Flemished splice, not a Texas tuck or turnback splice
- Heavy gauge stainless steel tag in accordance with ASME B30.9 & API RP2D
- 6x19 class IWRC EIP bright wire rope supplied standard
- Basket hitch capacity based on pin diameter of 5 times the diameter of the wire rope
- Quality controlled swaging process with paint verification
- Proof testing available on request
- Design factor of 5 to 1

How to order:

- Specify part number and length in feet when ordering

WARNING

See wire rope sling warnings page for warnings and inspection criteria

Dia. of Rope	Part Number BLP-013	Min. Sling Length ft-in.	Rated Capacities in Short Tons		
			Vertical	Choker	Vertical Basket
3/8"	01626205	2-8	2.9	2.0	5.8
1/2"	01626207	3-4	5.1	3.6	10.2
5/8"	01626209	4-0	7.9	5.5	15.8
3/4"	01626210	5-0	11.3	7.9	22.6
7/8"	01626211	5-8	15.3	10.7	30.6
1"	01626212	6-6	19.9	13.9	39.7













Note:

- Specify wire rope construction, grade, and finish if other than standard
- See weights page for weights

⚠️ WIRE ROPE SLING WARNINGS

When you inspect a wire rope sling, it shall be taken out of service immediately and returned for repair or replacement when any of the below defects are present.

WIRE ROPE SLINGS

Missing or illegible sling identification (tag)		Kinking, crushing, bird-caging, or any other damage to the rope structure	
For single part slings, 10 randomly distributed broken wires in one lay length or 5 broken wires in on one strand in one rope lay		Evidence of heat damage	
For cable-laid slings, 20 broken wires per braid		End attachments that are cracked, deformed, or worn	
For 6-part braided slings, 20 broken wires per braid		Severe corrosion of the rope, end attachments, or fittings	
For 8-part braided slings, 40 broken wires per braid		Damaged hooks per ASME B30.10	
Severe localized abrasion or scraping		Damaged rigging hardware per ASME B30.26	

and... Any condition that causes doubt about the continued use of the sling

Wire Rope Slings Identification, Inspection, Rigging Practices

Wire Rope Slings are designed and built for rugged lasting service. As with any quality product certain precautions and standards of treatment should be observed. Proper care will extend the useful life of a wire rope sling.

Follow the Guidelines set forth in ASME B30.9 “Slings” standard, OSHA 1910.184 and 1926.251.

Sling Identification

Each sling shall be marked to show the following:

- Name or Trademark of manufacturer
- Rated loads for the type(s) of hitch(es) used and the angle upon which it is based
- Diameter or size
- Number of legs, if more than one

Sling identification shall be done by the sling manufacturer, and should be maintained by the user so as to be legible during the life of the sling.

Inspection

Wire Rope Sling inspection falls into 3 categories. Initial, Frequent, and Periodic.

- **Initial Inspection**— Prior to use, all new, altered, modified, or repaired slings shall be inspected by a designated person to verify compliance with the applicable provisions of this chapter
- **Frequent Inspection**
 - o A visual inspection for damage shall be performed by the user or other designated person each day or shift the sling is used
 - o Conditions such as those listed in the removal criteria section or any other condition that may result in a hazard shall not be returned to service until approved by a qualified person
 - o Written records are not required for frequent inspections
- **Periodic Inspections**
 - o A complete inspection for damage to the sling shall be periodically performed by a designated person. Inspection shall be conducted on the entire length including splices, end attachments, and fittings. The sling shall be examined for conditions such as those listed in the removal criteria section and a determination made as to whether they constitute a hazard
 - o Periodic Inspection Frequency – Periodic inspection intervals shall not exceed 1 year. The frequency of periodic inspections should be based on:
 - Frequency of sling use
 - Severity of service condition
 - Nature of lifts being made
 - Experience gained on the service life of slings used in similar circumstances
 - o Guidelines for time intervals
 - Normal service – yearly
 - Severe service – monthly to quarterly
 - Special service – as recommended by a qualified person
 - o A written record of the most recent periodic inspection shall be maintained

Removal Criteria

A wire rope sling shall be removed from service if the following conditions are present.

- Missing or illegible sling identification (tag or markings)
- Broken wires
 - o For strand-laid or single-part slings, ten randomly broken wires in one rope lay, or five broken wire in one strand in one rope lay
 - o For cable laid slings, 20 broken wires per lay
 - o For six part braided slings, 20 broken wires per braid
 - o For eight part braided slings, 40 broken wires per braid
- Severe localized abrasion or scraping
- Kinking, crushing, bird-caging, or any other damage resulting in damage to the rope structure
- Evidence of heat damage
- End attachments that are cracked, deformed, or worn to the extent that the strength of the sling is substantially affected
- Severe corrosion of the rope, end attachments, or fittings
- Damaged hooks per ASME B30.10 Hooks standard (bent, stretched, or deformed hooks)
- Damaged rigging hardware per ASME B30.26
- Other conditions, including visible damage, that can cause doubt as to the continued use of the sling

Rigging Practices

- Slings shall be shortened or adjusted only by methods approved by the sling manufacturer or a qualified person
- Slings shall not be shortened or lengthened by knotting, twisting, or by wire rope clips
- The sling shall be hitched in a manner providing control of the load
- Slings in contact with edges, corners, or protrusions should be protected with a material of sufficient strength, thickness, and construction to prevent damage to the sling
- Shock loading should be avoided
- Loads should not be rested on the sling
- Slings should not be pulled from under the load when the load is resting on the sling
- Twisting and kinking shall be avoided
- During lifting, with or without load, personnel shall be alert for possible snagging
- When using multiple basket or choker hitches, the load should be rigged to prevent the sling from slipping or sliding along the load
- Slings should not be dragged on the floor or over an abrasive surface
- In a choker hitch, the choke point should only be on the sling body, not on a splice or fitting
- The load applied to the hook should be centered in the base of the hook to prevent point loading
- An object in the eye of a sling should not be wider than one half the length of the eye
- Sling and load shall not be allowed to rotate when hand tucked slings are used in a single leg vertical lift application. Care shall be taken to minimize sling rotation
- Slings made with wire rope clips shall not be used as a choker hitch

Environmental Considerations

Temperature





- Fiber core wire rope slings of all grades shall not be exposed to temperatures in excess of 180°F (82°C)
- When IWRC wire rope slings are to be used at temperatures above 400°F (204°C) or below -40°F (-40°C), the sling manufacturer should be consulted

Chemically Active Environments

- The strength of wire rope slings can be degraded by chemically active environments. This includes exposure to chemicals in the form of solids, liquids, gases, vapors, or fumes. The sling manufacturer or qualified person should be consulted before slings are used in chemically active environments




Sources:





ASME B30.9 “Slings” Standard
WRTB “Wire Rope Sling Users Manual” 3rd Edition
OSHA 1910.184 “Slings”
OSHA 1926.251 “Rigging Equipment for material handling”


Single Leg Wire Rope Slings, Series 100								
	BLP-100 standard eyes each end		BLP-101 standard eye and thimble		BLP-102 thimble eyes both ends		BLP-106 standard eye on top, w/ standard swage button bottom	
Weight in Lbs.	3' base	adder per foot	3' base	adder per foot	3' base	adder per foot	3' base	adder per foot
Dia.								
1/4"	0.6	0.116	0.64	0.116	0.67	0.116	0.56	0.116
3/8"	1.54	0.26	1.64	0.26	1.75	0.26	1.31	0.26
1/2"	3.15	0.46	3.37	0.46	3.59	0.46	2.76	0.46
5/8"	5.58	0.72	5.79	0.72	6	0.72	4.87	0.72
3/4"	8.96	1.04	9.5	1.04	10.04	1.04	7.34	1.04
7/8"	13.27	1.42	13.39	1.42	13.5	1.42	10.97	1.42
1"	19.01	1.85	19.68	1.85	20.36	1.85	15.33	1.85
1-1/8"	25.86	2.34	26.35	2.34	26.84	2.34	20.94	2.34
1-1/4"	34.46	2.89	37.75	2.89	41.05	2.89	28.06	2.89
1-3/8"	44.97	3.5	51.36	3.5	57.75	3.5		
1-1/2"	54.72	4.16	60.39	4.16	66.06	4.16		
1-3/4"	83.18	5.67	88.65	5.67	94.13	5.67		
2"	121.67	7.39	149.42	7.39	177.17	7.39		
2-1/4"	174.47	9.36	213.97	9.36	253.47	9.36		
2-1/2"	211.37	11.6	274.87	11.6	338.37	11.6		
2-3/4"	274.12	14						
3"	327.22	16.6						
3-1/2"	546.8	22.7						

Note: call for larger sizes





WIRE ROPE SLINGS

Single Leg Wire Rope Slings, Series 100						
	BLP-103 master link and thimble on top, and thimble on bottom		BLP-104 master link and thimble on top, thimble eye and eye hook on bottom		BLP-105 master link and thimble on top, w/ thimble eye and auto latching hook on bottom	
Weight in Lbs.						
Dia.	3' base	adder per foot	3' base	adder per foot	3' base	adder per foot
1/4"	1.49	0.116	2.11	0.116	3.3	0.116
3/8"	3.83	0.26	5.28	0.26	5.64	0.26
1/2"	8.44	0.46	12.69	0.46	10.25	0.46
5/8"	15.57	0.72	17.57	0.72	18.81	0.72
3/4"	19.61	1.04	23.86	1.04	25.57	1.04
7/8"	23.07	1.42	31.52	1.42	35.82	1.42
1"	36.61	1.85	51.73	1.85	49.36	1.85
1-1/8"	52.09	2.34	74.84	2.34	71.09	2.34
1-1/4"	66.3	2.89	105.8	2.89	85.3	2.89
1-3/8"	94.8	3.5	154.8	3.5	121.8	3.5
1-1/2"	103.11	4.16	208.11	4.16	130.11	4.16
1-3/4"	161.88	5.67	309.88	5.67	210.88	5.67
2"	264.87	7.39	492.87	7.39		



Single Leg Sliding Choker Hook Slings, Series 130								
	BLP-135 slip-through thimble on top, w/ sliding choker hook and small eye bottom		BLP-136 Slip-Through thimble on top, w/ sliding choker hook and thimble eye bottom		BLP-137 standard eye on top, w/ sliding choker hook and small eye bottom		BLP-138 standard eye on top, w/ sliding choker hook and thimble eye bottom	
Weight in Lbs.								
Dia.	3' base	adder per foot	3' base	adder per foot	3' base	adder per foot	3' base	adder per foot
3/8"	3.31	0.26	3.52	0.26	2.31	0.26	2.52	0.26
1/2"	5.84	0.46	6.35	0.46	4.34	0.46	4.85	0.46
5/8"	11.88	0.72	12.63	0.72	8.48	0.72	9.23	0.72
3/4"	15.31	1.04	16.85	1.04	11.91	1.04	13.45	1.04
7/8"	28.47	1.42	30.24	1.42	22.97	1.42	24.74	1.42
1"	34.21	1.85	37.35	1.85	28.71	1.85	31.85	1.85

Single Leg 6-part Flat Braided Slings, Series 160		
	BLP-160 with standard eye each end.	
Weight in Lbs.		
Dia. of Individual Components	3' base	Adder per foot
1/8"	0.7	0.2
3/16"	1.5	0.4
1/4"	2.4	0.7
5/16"	3.7	1.0
3/8"	5.0	1.5
7/16"	7.4	2.1
1/2"	9.5	2.8
9/16"	12.8	3.5
5/8"	15.1	4.3
3/4"	22.1	6.2
7/8"	30.2	8.5
1"	39.8	11.1



WIRE ROPE SLINGS

Two Leg Bridles, Series 200								
	Weight in Lbs.		Weight in Lbs.		Weight in Lbs.		Weight in Lbs.	
	3' base	adder per foot	3' base	adder per foot	3' base	adder per foot	3' base	adder per foot
Dia.								
1/4"	3.41	0.23	2.17	0.23		0.23		0.23
3/8"	8.48	0.52	5.58	0.52	6.91	0.52	7.12	0.52
1/2"	20.53	0.92	12.03	0.92	13.97	0.92	14.41	0.92
5/8"	38.47	1.44	21.57	1.44	26.95	1.44	27.37	1.44
3/4"	46.55	2.08	29.65	2.08	34.47	2.08	35.55	2.08
7/8"	66.81	2.84	36.57	2.84	55.74	2.84	55.97	2.84
1"	102.46	3.7	56.96	3.7	75.02	3.7	76.36	3.7
1-1/8"	157.93	4.68	78.93	4.68				
1-1/4"	186.35	5.78	107.35	5.78				
1-3/8"	272.54	7	152.54	7				
1-1/2"	248.17	8.32	169.17	8.32				
1-3/4"	376	11.34	256	11.34				
2"	652.05	14.78	442.05	14.78				

Note: call for larger sizes

Three Leg Bridles, Series 300				
	Weight in Lbs.		Weight in Lbs.	
	3' base	adder per foot	3' base	adder per foot
Dia.				
1/4"	5.4	0.348	3.54	0.348
3/8"	13.01	0.78	8.66	0.78
1/2"	33.1	1.38	20.35	1.38
5/8"	52.93	2.16	27.58	2.16
3/4"	71.72	3.12	46.37	3.12
7/8"	102.11	4.26	56.75	4.26
1"	154.57	5.55	86.32	5.55
1-1/8"	236.08	7.02	117.58	7.02
1-1/4"	278.7	8.67	160.2	8.67
1-3/8"	407.34	10.5	227.34	10.5
1-1/2"	384.43	12.48	265.93	12.48

Note: call for larger sizes

Four Leg Bridles, Series 400				
	Weight in Lbs.		Weight in Lbs.	
	3' base	adder per foot	3' base	adder per foot
Dia.				
1/4"	7.26	0.464	4.78	0.464
3/8"	17.66	1.04	11.86	1.04
1/2"	40.94	1.84	23.94	1.84
5/8"	67.38	2.88	33.58	2.88
3/4"	90.21	4.16	56.41	4.16
7/8"	139.74	5.68	79.26	5.68
1"	209.47	7.4	118.47	7.4
1-1/8"	319.47	9.36	161.47	9.36
1-1/4"	389.96	11.56	231.96	11.56




Note: call for larger sizes

Single Leg 8-Part Braids, Series 180				
	BLP-180 Single leg 8-part braided sling with slip through thimble on top, w/ sliding choker hook and casing thimble on bottom		BLP-181 Single leg 8-part braided sling with slip through thimble on top, w/ casing thimble on bottom	
Weight in Lbs.				
Dia.	3' base	adder per foot	3' base	adder per foot
1/8"	4.23	0.26	2.48	0.26
3/16"	7.61	0.59	4.36	0.59
1/4"	13.17	0.99	8.17	0.99
5/16"	18.87	1.56	12.37	1.56
3/8"	29.36	2.19	18.36	2.16
7/16"	50.15	3.15	24.15	3.15
1/2"	77.72	4.14	27.72	4.14




Two Leg 8-part Braids, Series 280				
	BLP-280 Two Leg 8-part braided sling with slip through thimble on top, w/ sliding choker hook and casing thimble on bottom		BLP-281 Two Leg 8-part braided sling with slip through thimble on top, w/ casing thimble on bottom	
Weight in Lbs.				
Dia.	3' base	adder per foot	3' base	adder per foot
1/8"	9.99	0.52	6.49	0.52
3/16"	20.06	1.18	13.56	1.18
1/4"	36.23	2.09	25.91	2.98
5/16"	53.99	3.11	40.99	3.12
3/8"	74.97	4.37	52.97	4.38
7/16"	125.55	6.3	73.55	6.3
1/2"	192.49	8.28	92.49	8.28


Three Leg 8-Part Braids, Series 380				
	BLP-380 Three Leg 8-part braided sling with slip through thimble on top, w/ sliding choker hook and casing thimble on bottom		BLP-381 Three Leg 8-part braided sling with slip through thimble on top, w/ casing thimble on bottom	
Weight in Lbs.				
Dia.	3' base	adder per foot	3' base	adder per foot
1/8"	17.55	0.78	12.3	0.78
3/16"	39.07	1.76	29.32	1.76
1/4"	56.25	3.13	41.25	3.13
5/16"	93.66	4.67	74.16	4.67
3/8"	125.13	6.56	92.13	6.56
7/16"	201.55	9.45	123.55	9.45
1/2"	284.26	12.42	134.26	12.42


Four Leg 8-Part Braids, Series 480				
	BLP-480 Four Leg 8-part braided sling with slip through thimble on top, w/ sliding choker hook and casing thimble on bottom		BLP-481 Four Leg 8-part braided sling with slip through thimble on top, w/ casing thimble on bottom	
Weight in Lbs.				
Dia.	3' base	adder per foot	3' base	adder per foot
1/8"	33.18	1.04	26.18	1.04
3/16"	67.47	2.34	54.47	2.34
1/4"	104.43	4.18	84.43	4.18
5/16"	126.58	6.23	100.58	6.23
3/8"	168.54	8.75	124.54	8.75
7/16"	288.3	12.6	184.3	12.6
1/2"	398.58	16.56	198.58	16.56

Socket Lines, Series 500						
Weight in Lbs.	BLP-500/501 Socket line with open swage socket each end		BLP-502/503 Socket line with open swage socket one end and closed socket other end		BLP-504/505 Socket line with closed swage socket each end	
Dia.	3' base	adder per foot	3' base	adder per foot	3' base	adder per foot
1/4"	1.39	0.116	1.2	0.116	1.01	0.116
3/8"	3.38	0.26	2.8	0.26	2.22	0.26
1/2"	5.54	0.46	4.88	0.46	4.22	0.46
5/8"	11.52	0.72	9.69	0.72	7.86	0.72
3/4"	19.06	1.04	16.09	1.04	13.12	1.04
7/8"	27.26	1.42	22.56	1.42	17.86	1.42
1"	41.15	1.85	33.75	1.85	26.35	1.85
1-1/8"	57.52	2.34	47.07	2.34	36.62	2.34
1-1/4"	80.17	2.89	65.42	2.89	50.67	2.89
1-3/8"	98	3.5	82.8	3.5	67.6	3.5
1-1/2"	129.48	4.16	108.98	4.16	88.48	4.16
1-3/4"	194.51	5.67	156.76	5.67	119.01	5.67
2"	314.67	7.39	257.67	7.39	200.67	7.39




WIRE ROPE SLINGS

Socket Lines, Series 600						
Weight in Lbs.	BLP-600/601 Socket line with open spelter socket each end		BLP-602/603 Socket line with open spelter socket one end and closed spelter socket other end		BLP-604/605 Socket line with closed spelter socket each end	
Dia.	3' base	adder per foot	3' base	adder per foot	3' base	adder per foot
1/4"	2.55	0.116	1.95	0.116	1.35	0.116
3/8"	3.38	0.26	2.83	0.26	2.28	0.26
1/2"	5.88	0.46	5.13	0.46	4.38	0.46
5/8"	10.16	0.72	8.66	0.72	7.16	0.72
3/4"	14.78	1.04	13.2	1.04	11.62	1.04
7/8"	23.42	1.42	21.09	1.42	18.76	1.42
1"	26.55	1.85	31.55	1.85	26.55	1.85
1-1/8"	50.02	2.34	42.77	2.34	35.52	2.34
1-1/4"	70.67	2.89	59.42	2.89	48.17	2.89
1-3/8"	72.5	3.5	61.25	3.5	50	3.5
1-1/2"	106.98	4.16	88.93	4.16	70.88	4.16
1-3/4"	181.01	5.67	156.26	5.67	131.51	5.67
2"	272.17	7.39	226.17	7.39	180.17	7.39
2-1/4"	362.08	9.36	300.08	9.36	238.08	9.36
2-1/2"	538.8	11.6	426.8	11.6	314.8	11.6
2-3/4"	672	14	577	14	482	14
3"	809.8	16.6	705.8	16.6	601.8	16.6
3-1/2"	1194.1	22.7	1031.1	22.7	868.1	22.7

Socket Lines, Series 600		
Weight in Lbs.	BLP-606/607 Socket line with mooring socket each end	
Dia.	3' base	adder per foot
2"	136.17	7.39
2-1/4"	180.08	9.36
2-1/2"	244.8	11.6
2-3/4"	318	14
3"	431.8	16.6
3-1/2"	626.1	22.7

Socket Lines, Series 600		
Weight in Lbs.	BLP-608 single leg with hawser thimble each end	
Dia.	3' base	adder per foot
5/8"	12.81	0.72
3/4"	13.96	1.04
7/8"	21.96	1.42
1"	26.07	1.85
1-1/8"	35.84	2.34
1-1/4"	41.83	2.89
1-3/8"	68.84	3.5
1-1/2"	77.16	4.16
1-3/4"	106.52	5.67
2"	144.46	7.39
2-1/4"	232.36	9.36
2-1/2"	341.4	11.6
2-3/4"	456.2	14
3"	494.8	16.6

WIRE ROPE SLINGS

Grommets, Series 010			
Weight in Lbs.	BLP-011 strand laid grommet	BLP-012 turn back swaged sleeve grommet	BLP-013 flemished swage sleeve grommet
Dia.	adder per foot	adder per foot	adder per foot
1/4"	0.116		0.116
3/8"	0.26	0.26	0.26
1/2"	0.46	0.46	0.46
5/8"	0.72	0.72	0.72
3/4"	1.04	1.04	1.04
7/8"	1.42	1.42	1.42
1"	1.85	1.85	1.85

* circumference measured

Alloy Chain Slings

Grade 80 and Grade 100



Campbell® Chain Sling Service Center

When selecting an alloy chain sling you will need to choose the type of coupling you prefer. The two types are (W) welded and (M) mechanically coupled.



Welded Coupling (W)

Mechanical Coupling (M)

Welded Coupling (W)

Features:

- Heat treated
- No pins
- Fewer moving parts
- Better Durability
- Tamper Proof
- Repairable



Mechanical Coupling (M)

Features:

- Assembled manually with pins, locking pins, and snap rings
- Fabricated quicker
- Repairable





Models:

- CO – Single leg alloy chain sling with alloy master link each end
- SSS – Single leg alloy chain sling with sling hook each end
- SGG – Single leg alloy chain sling with grab hook each end
- SSG – Single leg alloy chain sling with sling hook one end and grab hook other end
- SOG – Single leg alloy chain sling with master link one end and grab hook other end
- SOS – Single leg alloy chain sling with master link one end and sling hook other end
- SOF – Single leg alloy chain sling with master link one end and foundry hook other end
- SOJ – Single leg alloy chain sling with master link one end and J-hook other end
- SOSL – Single leg alloy chain sling with master link one end and self locking hook other end

Features:

- Heavy gauge stainless steel tag in accordance with ASME B30.9 and API RP2D
- Proof tested to 2X rated capacity
- Mechanically coupled or welded available
- Grade 100 alloy standard on 9/32" through 7/8"
- Grade 80 alloy standard on 7/32", 1", and 1-1/4"
- Hook latch optional on SSS, SSG, and SOS models
- Design factor 4 to 1

How to order:

- Include chain size, model, length, and coupling type
- Coupling types: M = mechanical
W = welded

⚠ WARNING

See alloy chain sling warnings page for warnings and inspection criteria

Chain Size	MM	Grade	Oblong Link			Rated Capacity Lbs.
			Nominal Material Size	Inside Dimensions		
				Width	Length	
7/32"	5.5	80	13/32"	1-1/2"	3"	2,100
9/32"	7	100	37/64"	2-1/2"	5"	4,300
3/8"	10	100	13/16"	3"	6"	8,800
1/2"	13	100	1-1/8"	4"	8"	15,000
5/8"	16	100	1-1/8"	4"	8"	22,600
3/4"	20	100	1-1/4"	4"	8"	35,300
7/8"	22	100	1-5/8"	5-1/4"	10-1/2"	42,700
1"	26	80	1-3/4"	6"	12"	47,700
1-1/4"	32	80	2"	7"	14"	72,300

Note:

- SOJ model has a maximum rated capacity of 3,600 lbs. and should only be made using 9/32" or 3/8" alloy chain sizes
- SOSL model only available in 9/32", 3/8", 1/2", 5/8", 3/4", 7/8", and 1" sizes
- Dimensions are approximate
- When using sling in choke hitch, reduce above rated capacity by 20%



DOG

Double leg alloy chain sling with master link one end and grab hooks other end

DOS

Double leg alloy chain sling with master link one end and sling hooks other end

DOF

Double leg alloy chain sling with master link one end and foundry hooks other end

DOSL

Double leg alloy chain sling with master link one end and self locking hooks other end

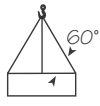
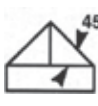
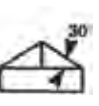
Features:

- Heavy gauge stainless steel tag in accordance with ASME B30.9 and API RP2D
- Proof tested to 2X rated capacity
- Mechanically coupled or welded available
- Grade 100 alloy standard on 9/32" through 7/8"
- Grade 80 alloy standard on 1" and 1-1/4"
- Hook latches optional on DOS model
- Design factor 4 to 1

How to order:

- Include chain size, model, length, and coupling type
- Coupling types: M = mechanical
W = welded

WARNING
See alloy chain sling warnings page for warnings and inspection criteria

Chain Size	MM	Grade	Oblong Link			Rated Capacity (Lbs.)		
			Nominal Material Size	Inside Dimensions				
				Width	Length			
9/32"	7	100	37/64"	2-1/2"	5"	7,400	6,100	4,300
3/8"	10	100	13/16"	3"	6"	15,200	12,400	8,800
1/2"	13	100	1-1/8"	4"	8"	26,000	21,200	15,000
5/8"	16	100	1-1/8"	4"	8"	39,100	32,000	22,600
3/4"	20	100	1-1/4"	4"	8"	61,100	49,900	35,300
7/8"	22	100	1-5/8"	5-1/4"	10-1/2"	74,000	60,400	42,700
1"	26	80	1-3/4"	6"	12"	82,600	67,400	47,700
1-1/4"	32	80	2"	7"	14"	125,200	102,200	72,300

Note:

- DOSL model only available in 9/32", 3/8", 1/2", 5/8", 3/4", 7/8", and 1" sizes
- Dimensions are approximate
- When using sling in choke hitch, reduce above rated capacity by 20%

ALLOY CHAIN SLINGS



TOG
Triple Leg alloy chain sling with master link one end and grab hooks other end

TOS
Triple leg alloy chain sling with master link one end and sling hooks other end

TOF
Triple leg alloy chain sling with master link one end and foundry hooks other end

TOSL
Triple leg alloy chain sling with master link one end and self locking hooks other end

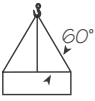
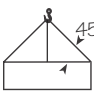
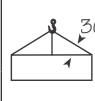
Features:

- Heavy gauge stainless steel tag in accordance with ASME B30.9 and API RP2D
- Proof tested to 2X rated capacity
- Mechanically coupled or welded available
- Grade 100 alloy standard on 9/32" through 7/8"
- Grade 80 alloy standard on 1" and 1-1/4"
- Hook latches optional on TOS model
- Design factor 4 to 1

How to order:

- Include chain size, model, length, and coupling type
- Coupling types: M = mechanical
W = welded

WARNING
See alloy chain sling warnings page for warnings and inspection criteria

Chain Size	MM	Grade	Oblong Link			Rated Capacity (lbs.)		
			Nominal Material Size	Inside Dimensions				
				Width	Length			
9/32"	7	100	13/16"	3"	6"	11,200	9,100	6,450
3/8"	10	100	1-1/8"	4"	8"	22,800	18,600	13,200
1/2"	13	100	1-1/4"	4"	8"	39,000	31,800	22,500
5/8"	16	100	1-5/8"	5-1/4"	10-1/2"	58,700	47,900	33,900
3/4"	20	100	1-7/8"	6"	12"	91,700	74,900	53,000
7/8"	22	100	2-1/4"	8"	16"	110,900	90,600	64,000
1"	26	80	2-1/4"	8"	16"	123,900	101,200	71,500
1-1/4"	32	80	2-3/4"	9"	16"	187,800	153,400	108,400

Note:

- TOSL model only available in 9/32", 3/8", 1/2", 5/8", 3/4", 7/8", and 1" sizes
- Dimensions are approximate
- When using sling in choke hitch, reduce above rated capacity by 20%



QQG
Quadruple leg alloy chain sling with master link one end and grab hooks other end

QOS
Quadruple leg alloy chain sling with master link one end and sling hooks other end

QOF
Quadruple leg alloy chain sling with master link one end and foundry hooks other end

QOSL
Quadruple leg alloy chain sling with master link one end and self locking hooks other end

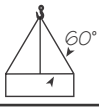
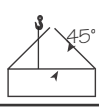
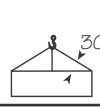
Features:

- Heavy gauge stainless steel tag in accordance with ASME B30.9 and API RP2D
- Proof tested to 2X rated capacity
- Mechanically coupled or welded available
- Grade 100 alloy standard on 9/32" through 7/8"
- Grade 80 alloy standard on 1" and 1-1/4"
- Hook latches optional on QOS model
- Design factor 4 to 1

How to order:

- Include chain size, model, length, and coupling type
- Coupling types: M = mechanical
W = welded

WARNING
See alloy chain sling warnings page for warnings and inspection criteria

Chain Size	MM	Grade	Oblong Link			Rated Capacity (lbs.)		
			Nominal Material Size	Inside Dimensions				
				Width	Length			
9/32"	7	100	13/16"	3"	6"	11,200	9,100	6,450
3/8"	10	100	1-1/8"	4"	8"	22,800	18,600	13,200
1/2"	13	100	1-1/4"	4"	8"	39,000	31,800	22,500
5/8"	16	100	1-5/8"	5-1/4"	10-1/2"	58,700	47,900	33,900
3/4"	20	100	1-7/8"	6"	12"	91,700	74,900	53,000
7/8"	22	100	2-1/4"	8"	16"	110,900	90,600	64,000
1"	26	80	2-1/4"	8"	16"	123,900	101,200	71,500
1-1/4"	32	80	2-3/4"	9"	16"	187,800	153,400	108,400

Note:

- QOSL model only available in 9/32", 3/8", 1/2", 5/8", 3/4", 7/8", and 1" sizes
- Dimensions are approximate
- When using sling in choke hitch, reduce above rated capacity by 20%



SAA

Single leg adjustable chain sling with master link and style A adjuster, with sling hook other end



SAB

Single leg adjustable chain sling style master link and style B adjuster, with sling hook other end

Features:

- Heavy gauge stainless steel tag in accordance with ASME B30.9 and API RP2D
- Proof tested to 2X rated capacity
- Mechanically coupled or welded available
- Grade 100 alloy standard on 9/32" through 7/8"
- Grade 80 alloy standard on 1" and 1-1/4"
- Hook latches optional
- Design factor 4 to 1

How to order:

- Include chain size, model, length, and coupling type
- Coupling types: M = mechanical
W = welded

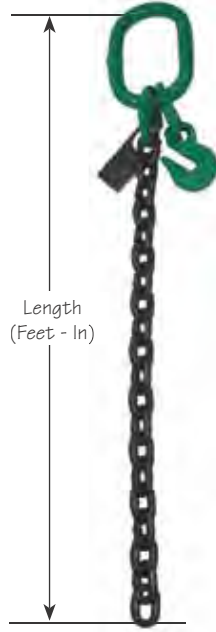
WARNING

See alloy chain sling warnings page for warnings and inspection criteria

Chain Size	MM	Grade	Oblong Link			Rated Capacity at 90° Lbs.
			Nominal Material Size	Inside Dimensions		
				Width	Length	
9/32"	7	100	37/64"	2-1/2"	5"	4,300
3/8"	10	100	13/16"	3"	6"	8,800
1/2"	13	100	1-1/8"	4"	8"	15,000
5/8"	16	100	1-1/8"	4"	8"	22,600
3/4"	20	100	1-5/8"	5-1/4"	10-1/2"	35,300
7/8"	22	100	1-5/8"	5-1/4"	10-1/2"	42,700
1"	26	80	1-3/4"	6"	12"	47,700
1-1/4"	32	80	2"	7"	14"	72,300

Note:

- Dimensions are approximate
- When using sling in choke hitch, reduce above rated capacity by 20%



Length
(Feet - In)

SALA

Single leg adjustable loop chain sling with master link and style A adjuster, blank other end



SALB

Single leg adjustable loop chain sling with master link and style B adjuster, blank other end

Features:

- Heavy gauge stainless steel tag in accordance with ASME B30.9 and API RP2D
- Proof tested to 2X rated capacity
- Mechanically coupled or welded available
- Grade 100 alloy standard on 9/32" through 7/8"
- Grade 80 alloy standard on 1" and 1-1/4"
- Design factor 4 to 1

How to order:

- Include chain size, model, length, and coupling type
- Coupling types: M = mechanical
W = welded

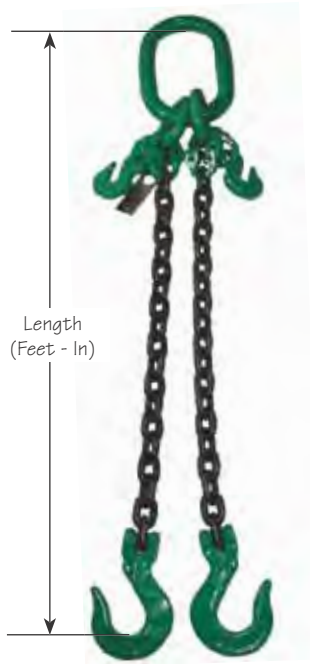
WARNING

See alloy chain sling warnings page for warnings and inspection criteria

Chain Size	MM	Grade	Oblong Link			Rated Capacity at 60° Lbs.
			Nominal Material Size	Inside Dimensions		
				Width	Length	
9/32"	7	100	37/64"	2-1/2"	5"	7,400
3/8"	10	100	13/16"	3"	6"	15,200
1/2"	13	100	1-1/8"	4"	8"	26,000
5/8"	16	100	1-1/4"	4"	8"	39,100
3/4"	20	100	1-5/8"	5-1/4"	10-1/2"	61,100
7/8"	22	100	1-7/8"	6"	12"	74,000
1"	26	80	2"	7"	14"	82,600
1-1/4"	32	80	2-1/4"	8"	16"	125,200

Note:

- Dimensions are approximate
- When using sling in choke hitch, reduce above rated capacity by 20%



DAA
Double leg adjustable chain sling with master link and style A adjuster, with sling hooks other end



DAB
Double leg adjustable chain sling with master link and style B adjuster, with sling hooks other end

Features:

- Heavy gauge stainless steel tag in accordance with ASME B30.9 and API RP2D
- Proof tested to 2X rated capacity
- Mechanically coupled or welded available
- Grade 100 alloy standard on 9/32" through 7/8"
- Grade 80 alloy standard on 1" and 1-1/4"
- Hook latches optional
- Design factor 4 to 1

How to order:

- Include chain size, model, length, and coupling type
- Coupling types: M = mechanical
W = welded

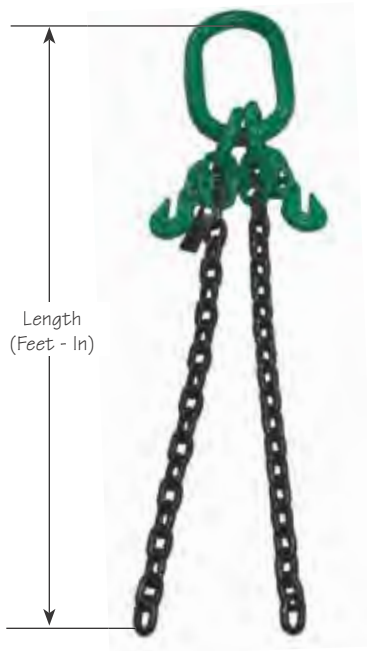
⚠ WARNING

See alloy chain sling warnings page for warnings and inspection criteria

Chain Size	MM	Grade	Oblong Link			Rated Capacity at 60° Lbs.
			Nominal Material Size	Inside Dimensions		
				Width	Length	
9/32"	7	100	37/64"	2-1/2"	5"	7,400
3/8"	10	100	13/16"	3"	6"	15,200
1/2"	13	100	1-1/8"	4"	8"	26,000
5/8"	16	100	1-1/4"	4"	8"	39,100
3/4"	20	100	1-5/8"	5-1/4"	10-1/2"	61,100
7/8"	22	100	1-7/8"	6"	12"	74,000
1"	26	80	2"	7"	14"	82,600
1-1/4"	32	80	2-1/4"	8"	16"	125,200

Note:

- Dimensions are approximate
- When using sling in choke hitch, reduce above rated capacity by 20%



DALA

Double leg adjustable loop chain sling with master link and style A adjuster, blank other ends



DALB

Double leg adjustable loop chain sling with master link and style B adjuster, blank other ends

ALLOY CHAIN SLINGS

Features:

- Heavy gauge stainless steel tag in accordance with ASME B30.9 and API RP2D
- Proof tested to 2X rated capacity
- Mechanically coupled or welded available
- Grade 100 alloy standard on 9/32" through 7/8"
- Grade 80 alloy standard on 1" and 1-1/4"
- Design factor 4 to 1

How to order:

- Include chain size, model, length, and coupling type
- Coupling types: M = mechanical
W = welded

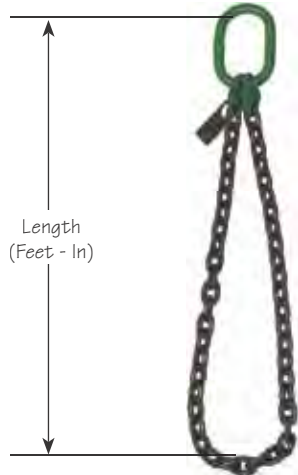
⚠ WARNING

See alloy chain sling warnings page for warnings and inspection criteria

Chain Size	MM	Grade	Oblong Link			Rated Capacity at 60° Lbs.
			Nominal Material Size	Inside Dimensions		
				Width	Length	
9/32"	7	100	13/16"	3"	6"	11,200
3/8"	10	100	1-1/8"	4"	8"	22,800
1/2"	13	100	1-1/4"	4"	8"	39,000
5/8"	16	100	1-5/8"	5-1/4"	10-1/2"	58,700
3/4"	20	100	1-7/8"	6"	12"	91,700
7/8"	22	100	2-1/4"	8"	16"	110,900
1"	26	80	2-1/4"	8"	16"	123,900
1-1/4"	32	80	2-3/4"	9"	16"	187,800

Note:

- Dimensions are approximate
- When using sling in choke hitch, reduce above rated capacity by 20%



SB

Single basket alloy chain sling
with master link



DB

Double basket alloy chain sling
with master link

Features:

- Heavy gauge stainless steel tag in accordance with ASME B30.9 and API RP2D
- Proof tested to 2X rated capacity
- Mechanically coupled or welded available
- Grade 100 alloy standard on 9/32" through 7/8"
- Grade 80 alloy standard on 1" and 1-1/4"
- Design factor 4 to 1

How to order:

- Include chain size, model, length, and coupling type
- Coupling types: M = mechanical
W = welded

WARNING

See alloy chain sling warnings page
for warnings and inspection criteria

SB – Single Basket

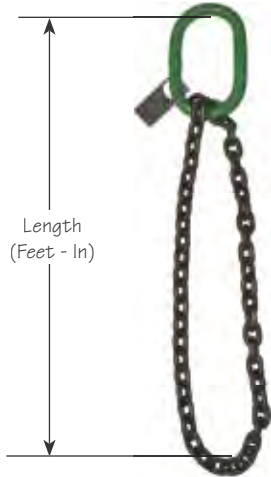
Chain Size	MM	Grade	Oblong Link			Rated Capacity at 60° Lbs.
			Nominal Material Size	Inside Dimensions		
				Width	Length	
9/32"	7	100	37/64"	2-1/2"	5"	7,400
3/8"	10	100	13/16"	3"	6"	15,200
1/2"	13	100	1-1/8"	4"	8"	26,000
5/8"	16	100	1-1/4"	4"	8"	39,100
3/4"	20	100	1-5/8"	5-1/4"	10-1/2"	61,100
7/8"	22	100	1-7/8"	6"	12"	74,000
1"	26	80	2"	7"	14"	82,600
1-1/4"	32	80	2-1/4"	8"	16"	125,200

DB – Double Basket

Chain Size	MM	Grade	Oblong Link			Rated Capacity at 60° Lbs.
			Nominal Material Size	Inside Dimensions		
				Width	Length	
9/32"	7	100	13/16"	3"	6"	11,200
3/8"	10	100	1-1/8"	4"	8"	22,800
1/2"	13	100	1-1/4"	4"	8"	39,000
5/8"	16	100	1-5/8"	5-1/4"	10-1/2"	58,700
3/4"	20	100	1-7/8"	6"	12"	91,700
7/8"	22	100	2-1/4"	8"	16"	110,900
1"	26	80	2-1/4"	8"	16"	123,900
1-1/4"	32	80	2-3/4"	9"	16"	187,800

Note:

- Dimensions are approximate
- When using sling in choke hitch, reduce above rated capacity by 20%



SE

Single endless basket alloy chain sling with master link



DE

Double endless basket alloy chain sling with master link

Features:

- Heavy gauge stainless steel tag in accordance with ASME B30.9 and API RP2D
- Proof tested to 2X rated capacity
- Mechanically coupled or welded available
- Grade 100 alloy standard on 9/32" through 7/8"
- Grade 80 alloy standard on 1" and 1-1/4"
- Design factor 4 to 1

How to order:

- Include chain size, model, length, and coupling type
- Coupling types: M = mechanical
W = welded

⚠ WARNING

See alloy chain sling warnings page for warnings and inspection criteria

SE –Single Endless

Chain Size	MM	Grade	Oblong Link			Rated Capacity at 60° Lbs.
			Nominal Material Size	Inside Dimensions		
				Width	Length	
9/32"	7	100	37/64"	2-1/2"	5"	4,300
3/8"	10	100	13/16"	3"	6"	8,800
1/2"	13	100	1-1/8"	4"	8"	15,000
5/8"	16	100	1-1/8"	4"	8"	22,600
3/4"	20	100	1-1/4"	4"	8"	35,300
7/8"	22	100	1-5/8"	5-1/4"	10-1/2"	42,700
1"	26	80	2"	7"	14"	47,700
1-1/4"	32	80	2-1/4"	8"	16"	72,300

DE – Double Endless

Chain Size	MM	Grade	Oblong Link			Rated Capacity at 60° Lbs.
			Nominal Material Size	Inside Dimensions		
				Width	Length	
9/32"	7	100	13/16"	3"	6"	7,400
3/8"	10	100	1-1/8"	4"	8"	15,200
1/2"	13	100	1-1/4"	4"	8"	26,000
5/8"	16	100	1-5/8"	5-1/4"	10-1/2"	39,100
3/4"	20	100	1-7/8"	6"	12"	61,100
7/8"	22	100	1-7/8"	6"	12"	74,000
1"	26	80	2"	7"	14"	82,600
1-1/4"	32	80	2-1/4"	8"	16"	125,200

Note:

- Dimensions are approximate
- When using sling in choke hitch, reduce above rated capacity by 20%

ALLOY CHAIN SLINGS



Length
(Feet - In)

DO

Double leg alloy chain sling with master link and blank ends

Features:

- Heavy gauge stainless steel tag in accordance with ASME B30.9 and API RP2D
- Proof tested to 2X rated capacity
- Mechanically coupled or welded available
- Grade 100 alloy standard on 9/32" through 7/8"
- Grade 80 alloy standard on 1" and 1-1/4"
- Design factor 4 to 1

How to order:

- Include chain size, model, length, and coupling type
- Coupling types: M = mechanical
W = welded

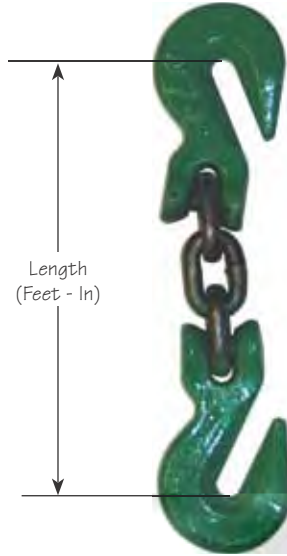
WARNING
See alloy chain sling warnings page for warnings and inspection criteria

Chain Size	MM	Grade	Top Oblong Link			Rated Capacity at 60° Lbs.
			Nominal Material Size	Inside Dimensions		
				Width	Length	
9/32"	7	100	37/64"	2-1/2"	5"	7,400
3/8"	10	100	13/16"	3"	6"	15,200
1/2"	13	100	1-1/8"	4"	8"	26,000
5/8"	16	100	1-1/4"	4"	8"	39,100
3/4"	20	100	1-5/8"	5-1/4"	10-1/2"	61,100
7/8"	22	100	1-7/8"	6"	12"	74,000
1"	26	80	2"	7"	14"	82,600
1-1/4"	32	80	2-1/4"	8"	16"	125,200

Note:

- Dimensions are approximate
- When using sling in choke hitch, reduce above rated capacity by 20%

ALLOY CHAIN SLINGS



CS

Single leg alloy chain shortener with grab hook each end.

Features:

- Heavy gauge stainless steel tag in accordance with ASME B30.9 and API RP2D
- Proof tested to 2X rated capacity
- Mechanically coupled or welded available
- Grade 100 alloy standard on 9/32" through 7/8"
- Grade 80 alloy standard on 1" and 1-1/4"
- Design factor 4 to 1

How to order:

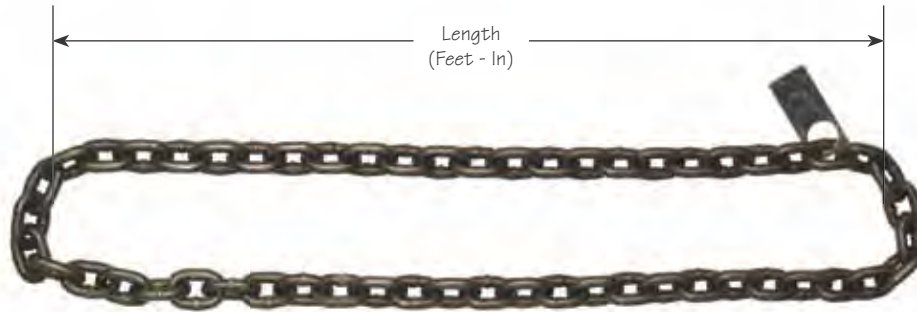
- Include chain size, model, length, and coupling type
- Coupling types: M = mechanical
W = welded

WARNING
See alloy chain sling warnings page for warnings and inspection criteria

Chain Size	MM	Grade	Length	Rated Capacity (lbs.)
9/32"	7	100	1'1"	4,300
3/8"	10	100	1'3"	8,800
1/2"	13	100	1'8"	15,000
5/8"	16	100	2'0"	22,600
3/4"	20	100	2'4"	35,300
7/8"	22	100	2'8"	42,700
1"	26	80	3'1"	47,700
1-1/4"	32	80	3'10"	72,300

Note:

- Dimensions are approximate



ENC
Endless alloy chain sling

Features:

- Heavy gauge stainless steel tag in accordance with ASME B30.9 and API RP2D
- Proof tested to 2X rated capacity
- Mechanically coupled or welded available
- Grade 100 alloy standard on 9/32" through 7/8"
- Grade 80 alloy standard on 1" and 1-1/4"
- Design factor 4 to 1

How to order:

- Include chain size, model, length, and coupling type
- Coupling types: W = welded only

⚠ WARNING

See alloy chain sling warnings page for warnings and inspection criteria

Chain Size	MM	Grade	Rated Capacity (lbs.)
9/32"	7	100	4,300
3/8"	10	100	8,800
1/2"	13	100	15,000
5/8"	16	100	22,600
3/4"	20	100	35,300
7/8"	22	100	42,700
1"	26	80	47,700
1-1/4"	32	80	72,300

Note:

- Dimensions are approximate
- When using sling in choke hitch, reduce above rated capacity by 20%

ALLOY CHAIN SLINGS



SS
Single leg alloy chain with
sling hook one end only

SG
Single leg alloy chain with
grab hook one end only

SO
Single leg alloy chain with
master link one end only

Features:

- Heavy gauge stainless steel tag in accordance with ASME B30.9 and API RP2D
- Proof tested to 2X rated capacity
- Mechanically coupled or welded available
- Grade 100 alloy standard on 9/32" through 7/8"
- Grade 80 alloy standard on 1" and 1-1/4"
- Design factor 4 to 1

How to order:

- Include chain size, model, length, and coupling type
- Coupling types: M = mechanical
W = welded

WARNING
See alloy chain sling warnings page
for warnings and inspection criteria

Chain Size	MM	Grade	Rated Capacity (lbs.)
9/32"	7	100	4,300
3/8"	10	100	8,800
1/2"	13	100	15,000
5/8"	16	100	22,600
3/4"	20	100	35,300
7/8"	22	100	42,700
1"	26	80	47,700
1-1/4"	32	80	72,300

Note:

- Dimensions are approximate
- When using sling in choke hitch, reduce above rated capacity by 20%

⚠️ ALLOY CHAIN SLING WARNINGS

When you inspect an alloy chain sling, it shall be taken out of service immediately and returned for repair or replacement when any of the below defects are present.

Missing or illegible sling identification (tag)		Lack of ability of chain or components to hinge freely	
Cracks or breaks to any part of the sling		Weld Splatter	
Excessive wear, nicks, or gouges		Damaged hooks per ASME B30.10	
Stretched chain links or components		Damaged rigging hardware per ASME B30.26	
Bent, twisted, or deformed chain links or components			
Evidence of heat damage			
Excessive pitting or corrosion			

and... Any condition that causes doubt about the continued use of the sling

Alloy Chain Slings Identification, Inspection, Rigging Practices

Welded and mechanically coupled products are designed and built for rugged lasting service. As with any quality product certain precautions and standards of treatment should be observed. Proper care will extend the useful life of the chain sling.

Follow the Guidelines set forth in ASME B30.9 “Slings” standard, OSHA 1910.184 and 1926.251.

Sling Identification

- Each sling shall be marked to show
- Name or trademark of manufacturer
- Grade
- Nominal Chain Size
- Number of Legs
- Rated Loads for the vertical hitch and bridle hitch and the angle upon which it is based
- Length
- Individual sling identification (serial numbers)

Sling identification shall be done by the sling manufacturer and should be maintained by the user so as to be legible during the life of the sling.

Inspection

Alloy Chain Sling inspection falls into 3 categories. Initial, Frequent, and Periodic.

- **Initial Inspection**– Prior to use, all new, altered, modified, or repaired slings shall be inspected by a designated person to verify compliance
- **Frequent Inspection**
 - o A visual inspection for damage shall be performed by the user or other designated person each day or shift the sling is used
 - o Conditions such as those listed in the removal criteria section or any other condition that may result in a hazard shall not be returned to service until approved by a qualified person
 - o Written records are not required for frequent inspections
- **Periodic Inspections**
 - o A complete inspection for damage to the sling shall be periodically performed by a designated person. Each link and component shall be examined individually; taking care to expose and examine all surfaces including the inner link surfaces. The sling shall be examined for conditions such as those listed below in removal criteria section, and a determination made as to whether they constitute a hazard
 - o Periodic Inspection Frequency – Periodic inspection intervals shall not exceed 1 year. The frequency of periodic inspections should be based on:
 - Frequency of sling use
 - Severity of service condition
 - Nature of lifts being made
 - Experience gained on the service life of slings used in similar circumstances
 - o Guidelines for time intervals
 - Normal service – yearly
 - Severe service – monthly to quarterly
 - Special service – as recommended by a qualified person
 - o A written record of the most recent periodic inspection shall be maintained

Removal Criteria

An alloy steel chain sling shall be removed from service if conditions such as the following are present:

- Missing or illegible sling identification
- Cracks or breaks
- Excessive wear, nicks, or gouges. Minimum thickness on chain links shall not be below the values listed in the table on the next page
- Stretched chain links or damage
- Bent, twisted, or deformed chain links or components
- Evidence of heat damage
- Excessive pitting or corrosion
- Lack of ability of chain or components to hinge freely
- Weld splatter
- Hook damage
- Rigging hardware damage
- Other conditions, including visual damage, that cause doubt as to the continued use of the sling

Minimum Allowable Thickness at Any Point on a Link

Nominal Chain or Coupling Link Size		Minimum Allowable Thickness at ANY point on the Link	
In.	Mm	In.	Mm
7/32"	5.5	0.189	4.80
9/32"	7	0.239	6.07
5/16"	8	0.273	6.93
3/8"	10	0.342	8.69
1/2"	13	0.443	11.26
5/8"	16	0.546	13.87
3/4"	20	0.687	17.45
7/8"	22	0.750	19.05
1"	26	0.887	22.53
1-1/4"	32	1.091	27.71

Rigging Practices

- Slings shall be shortened or adjusted only by methods approved by the sling manufacturer or a qualified person
- Slings shall not be shortened or lengthened by knotting or twisting
- The sling shall be hitched in a manner providing control of the load
- Slings in contact with edges, corners or protrusions should be protected with a material of sufficient strength, thickness, and construction to prevent damage
- Shock loading should be avoided
- Loads should not be rested on the sling
- Slings should not be pulled from under a load when the load is resting on the sling
- Twisting and kinking shall be avoided
- During lifting, with or without load, personnel shall be alert for possible snagging
- When using multiple basket or choker hitches, the load should be rigged to prevent the sling from slipping or sliding along the load
- When using a basket hitch, the legs of a sling should contain or support the load from the sides, above the center of gravity, so the load remains under control
- Slings should not be dragged on the floor or over an abrasive surface
- In a choker hitch, the choke point should only be on the sling body, never on a fitting
- In a choker hitch, an angle of choke less than 120 degrees should not be used without reducing the rated load (contact BLP)
- Slings should not be constricted, bunched, or pinched by the load, hook, or any fitting
- The load applied to the hook should be centered in the base of the hook to prevent point loading on the hook, unless the hook is designed for point loading

Environmental Considerations

- Slings should be stored in an area where they will not be subjected to mechanical damage, corrosive action, moisture, extreme temperatures or kinking
- When used at or in contact with extreme temperatures, use the chart on the next page for the effects of temperature

Campbell Chain engineers should be consulted when heat treated chain is used at unusual temperatures (under -20°F [-29°C]) or over 400°F [204°C] or where special applications are required.

Effect of Elevated Temperatures on the Working Load Limit of Alloy Chain

Temperature		Grade of Chain			
F°	C°	Grade 80 (System 8)		Grade 100 (System 10)	
		Reduction of Rated Capacity WHILE at Temperature	Reduction of Rated Capacity AFTER EXPOSURE to Temperature	Reduction of Rated Capacity WHILE at Temperature	Reduction of Rated Capacity AFTER EXPOSURE to Temperature
<400°	<204°	None	None	None	None
400°	204°	10%	None	15%	None
500°	260°	15%	None	25%	5%
600°	316°	20%	5%	30%	15%
700°	371°	30%	10%	40%	20%
800°	427°	40%	15%	50%	25%
900°	482°	50%	20%	60%	30%
1000°	538°	60%	25%	70%	35%
>1000°	>538°	OSHA requires that any chain sling which has experienced temperatures in excess of 1000° F be removed from service.			

Sources:

ASME B30.9 “Slings” Standard

OSHA 1910.184 “Slings”

OSHA 1926.251 “Rigging Equipment for material handling”

Campbell Material Handling Products catalog, August 2008

Alloy Chain Slings Important Terms

Rated Capacity

Rated Capacity (RC) – The “rated capacity” is the maximum combined static and dynamic load in pounds or Kilograms which should ever be applied to the product in service, even when the product is new, and when the load is uniformly applied in direct tension to the product.

Proof Test

The “proof test” is a quality control test applied to chain for the purpose of verifying weld and material quality. It is the minimum force in pounds or newtons that the chain has withstood in direct tension as a part of the manufacturing process. Proof Testing assures that the chain is more than capable of performing at its rated working load limit. Proof test loads are a manufacturing integrity test and shall not be used as criteria for service or design purposes. All Campbell chain and components are proof tested in accordance with the applicable ASTM, NACM, OSHA, and ASME requirements.

Certificate of Test and Tags

Bishop Lifting Products, Inc. and Campbell Chain provide information in several forms that enables purchasers and users to operate safely and effectively in conformity with ASME B30.9 and OSHA requirements. The drop forged or stainless steel tag is attached to each chain sling and provides the following:

1. Grade of Chain
2. Size (chain)
3. Reach (length)
4. Rated Capacity
5. Serial Number
6. Type

A certificate of test is provided for each chain sling manufactured at Bishop Lifting Products, Inc. The Certificate of test contains all of the information provided on the identification tag, plus the Proof Test load as required by OSHA.

Basic Types of Chain Slings

Slings are identified throughout the industry by symbols.

First Symbol (Basic Type)





- S – Single leg
- C – Single leg with master links only (no hooks)
- D – Double leg
- T – Triple leg
- Q – Quadruple leg





Second Symbol

- O – Oblong link on top
- A – Adjustable type sling
- S – Sling hook one end
- G – Grab hook one end
- F – Foundry hook one end





Third Symbol





- S – Sling hook
- G – Grab hook
- F – Foundry hook
- SL – Self-locking hook
- PC – Plate clamps
- X – Special fittings





Single Leg Chain Slings								
	CO		SSS		SGG		SSG	
Size	3' base	adder/ft.	3' base	adder/ft.	3' base	adder/ft.	3' base	adder/ft.
9/32"	5.77	0.74	4.36	0.74	2.92	0.74	3.64	0.74
3/8"	8.7	1.48	8.86	1.48	6.93	1.48	7.89	1.48
1/2"	19.61	2.5	15.9	2.5	11.15	2.5	13.53	2.5
5/8"	22.75	3.79	23.97	3.79	18.97	3.79	21.47	3.79
3/4"	32.73	6.1	43.77	6.1	34.05	6.1	38.91	6.1
7/8"	49.37	7.75	47.7	7.75	38.66	7.75	43.18	7.75
1"	74.47	9.65	66.55	9.65	55.82	9.65	61.18	9.65
1-1/4"	99.46	15.25	88.47	15.25	96.64	15.25	92.55	15.25

Single Leg Chain Sling (Continued)								
	SOG		SOS		SOF		SOSL	
Size	3' base	adder/ft.	3' base	adder/ft.	3' base	adder/ft.	3' base	adder/ft.
9/32"	4.35	0.74	5.06	0.74	6.08	0.74	6.05	0.74
3/8"	7.81	1.48	8.78	1.48	10	1.48	9.99	1.48
1/2"	15.38	2.5	17.76	2.5	19.78	2.5	20.88	2.5
5/8"	20.86	3.79	23.36	3.79	26.47	3.79	27.74	3.79
3/4"	33.39	6.1	38.25	6.1	38.52	6.1	35.7	6.1
7/8"	44.01	7.75	48.53	7.75	54.68	7.75	56.1	7.75
1"	65.15	9.65	70.51	9.65	79.85	9.65	91.58	9.65
1-1/4"	98.05	15.25	93.96	15.25	115.18	15.25		



ALLOY CHAIN SLINGS



Double Leg Chain Slings								
	DOG		DOS		DOF		DOSL	
Size	3' base	adder/ft.	3' base	adder/ft.	3' base	adder/ft.	3' base	adder/ft.
9/32"	6.79	1.48	8.22	1.48	10.27	1.48	10.2	1.48
3/8"	13	2.96	14.92	2.96	17.37	2.96	17.35	2.96
1/2"	23.98	5	28.73	5	32.78	5	34.98	5
5/8"	37.36	7.58	42.36	7.58	48.58	7.58	51.13	7.58
3/4"	64.79	12.2	74.5	12.2	75.05	12.2	69.4	12.2
7/8"	77	15.5	86.04	15.5	98.34	15.5	101.18	15.5
1"	107.39	19.3	118.12	19.3	136.8	19.3	160.26	19.3
1-1/4"	169.61	30.5	161.45	30.5	203.88	30.5		

Triple Leg Chain Slings								
	TOG		TOS		TOF		TOSL	
Size	3' base	adder/ft.	3' base	adder/ft.	3' base	adder/ft.	3' base	adder/ft.
9/32"	9.79	2.22	11.94	2.22	15	2.22	14.9	2.22
3/8"	21.58	4.44	24.47	4.44	28.13	4.44	28.1	4.44
1/2"	35	7.5	42.13	7.5	48.2	7.5	51.5	7.5
5/8"	58.8	11.37	66.31	11.37	75.64	11.37	79.46	11.37
3/4"	95.25	18.3	109.83	18.3	110.64	18.3	102.17	18.3
7/8"	118.76	23.25	132.32	23.25	150.77	23.25	155.03	23.25
1"	153.75	28.95	169.84	28.95	197.86	28.95	233.05	28.95
1-1/4"	173.42	45.75	248.87	45.75	312.52	45.75		

Quadruple Leg Chain Slings								
	QOG		QOS		QOF		QOSL	
Size	3' base	adder/ft.	3' base	adder/ft.	3' base	adder/ft.	3' base	adder/ft.
9/32"	13.27	2.96	16.13	2.96	20.21	2.96	20.07	2.96
3/8"	27.81	5.92	31.66	5.92	36.54	5.92	36.51	5.92
1/2"	46.6	10	55.8	10	63.6	10	68.3	10
5/8"	77.37	15.16	87.39	15.16	99.82	15.16	104.92	15.16
3/4"	126.52	24.4	145.96	24.4	147.04	24.4	135.74	24.4
7/8"	136.75	31	154.82	31	179.43	31	185.1	31
1"	187.01	38.6	208.46	38.6	245.82	38.6	292.74	38.6
1-1/4"	318.92	61	302.59	61	387.46	61		

ALLOY CHAIN
SLINGS

Single Leg Chain Slings, Adjustable				
	SAA		SAB	
Size	3' base	adder/ft.	3' base	adder/ft.
9/32"	5.83	0.74	6.57	0.74
3/8"	10.93	1.48	12.41	1.48
1/2"	22.01	2.5	24.51	2.5
5/8"	31.26	3.79	35.05	3.79
3/4"	53.05	6.1	59.15	6.1
7/8"	65.08	7.75	72.83	7.75
1"	98.84	9.65	108.49	9.65
1-1/4"	147.8	15.25	163.05	15.25

Single Leg Chain Slings, Adjustable Loop				
	SALA		SALB	
Size	3' base	adder/ft.	3' base	adder/ft.
9/32"	4.76	0.74	5.5	0.74
3/8"	8.72	1.48	10.2	1.48
1/2"	17.81	2.5	20.31	2.5
5/8"	24.96	3.79	28.75	3.79
3/4"	40.32	6.1	46.42	6.1
7/8"	52.86	7.75	60.61	7.75
1"	80.04	9.65	89.69	9.65
1-1/4"	126.44	15.25	141.69	15.25



Double Leg Chain Slings, Adjustable				
	DAA		DAB	
Size	3' base	adder/ft.	3' base	adder/ft.
9/32"	9.76	1.48	11.24	1.48
3/8"	19.22	2.96	22.18	2.96
1/2"	37.23	5	42.23	5
5/8"	58.16	7.58	65.74	7.58
3/4"	104.1	12.2	116.3	12.2
7/8"	119.14	15.5	134.64	15.5
1"	174.78	19.3	194.08	19.3
1-1/4"	269.13	30.5	299.63	30.5

Double Leg Chain Slings, Adjustable Loop				
	DALA		DALB	
Size	3' base	adder/ft.	3' base	adder/ft.
9/32"	7.63	1.48	9.11	1.48
3/8"	14.81	2.96	17.77	2.96
1/2"	28.83	5	33.83	5
5/8"	45.56	7.58	53.14	7.58
3/4"	78.63	12.2	90.83	12.2
7/8"	94.69	15.5	110.19	15.5
1"	137.18	19.3	156.48	19.3
1-1/4"	226.41	30.5	256.91	30.5

Basket Chain Slings				
	SB		DB	
Size	3' base	adder/ft.	3' base	adder/ft.
9/32"	6.09	1.48	11.86	2.96
3/8"	10.51	2.96	22.83	5.92
1/2"	20.33	5	39	10
5/8"	29.76	7.58	62.18	15.16
3/4"	49.03	12.2	95.02	24.4
7/8"	61.59	15.5	105.93	31
1"	80.52	19.3	133.27	38.6
1-1/4"	118.73	30.5	217.15	61

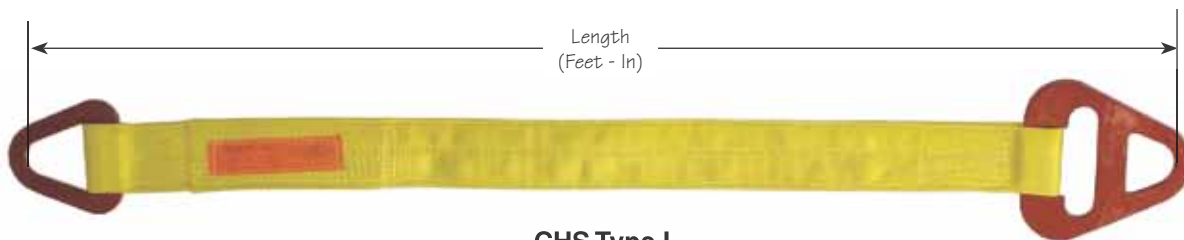
Endless Basket Chain Slings				
	SE		DE	
Size	3' base	adder/ft.	3' base	adder/ft.
9/32"	5.9	1.48	10.77	2.96
3/8"	10.27	2.96	21.53	5.92
1/2"	19.38	5	36.3	10
5/8"	28.31	7.58	56.91	15.16
3/4"	46.93	12.2	85.93	24.4
7/8"	60.65	15.5	109.53	31
1"	76.82	19.3	133.27	38.6
1-1/4"	111.83	30.5	217.15	61

ALLOY CHAIN
SLINGS

Chain Shortener & Endless Chain Slings			
	CS	ENC	
Size	3 links	3' base	adder/ft.
9/32"	1.16	4.62	1.48
3/8"	3.65	9.12	2.96
1/2"	6.18	15.95	5
5/8"	12.23	24.19	7.58
3/4"	24.69	38.7	12.2
7/8"	38.33	47.44	15.5
1"	63.41	61.6	19.3
1-1/4"	121.03	98.4	30.5

Web Slings





CHS Type I

Nylon or Polyester choker/basket web slings with alloy steel fittings

Features:

- Heavy duty 9800 lb. webbing with UV inhibitors
- Orange vinyl tag with clear vinyl cover to protect data
- Alloy steel end fittings
- 3-7% stretch with polyester
- 6-10% stretch with nylon
- Proof testing available upon request
- Design factor of 5 to 1

How to order:

- Combine model, length in feet, and type



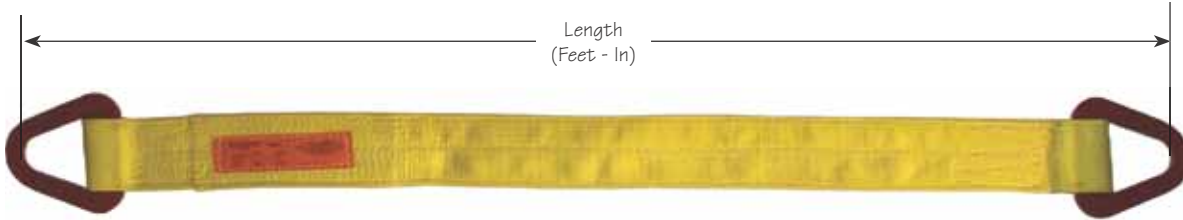
WARNING

See web sling warnings page for warnings and inspection criteria

Width	Nylon Part Number			Polyester Part Number			Capacities in Lbs.		
	Model	Length	Type	Model	Length	Type	Choker	Vertical	Basket
2"	02CHS1X	*	I	02CHS1PX	*	I	2,480	3,100	6,200
2"	02CHS2X	*	I	02CHS2PX	*	I	4,960	6,200	12,400
2"	02CHS4X	*	I	02CHS4PX	*	I	8,800	11,000	22,000
3"	03CHS1X	*	I	03CHS1PX	*	I	3,760	4,700	9,400
3"	03CHS2X	*	I	03CHS2PX	*	I	7,040	8,800	17,600
3"	03CHS4X	*	I	03CHS4PX	*	I	13,160	16,450	32,900
4"	04CHS1X	*	I	04CHS1PX	*	I	4,960	6,200	12,400
4"	04CHS2X	*	I	04CHS2PX	*	I	8,800	11,000	22,000
4"	04CHS4X	*	I	04CHS4PX	*	I	16,320	20,400	40,800
6"	06CHS1X	*	I	06CHS1PX	*	I	7,440	9,300	18,600
6"	06CHS2X	*	I	06CHS2PX	*	I	13,200	16,500	33,000
6"	06CHS4X	*	I	06CHS4PX	*	I	24,480	30,600	61,200
8"	08CHS1X	*	I	08CHSP1X	*	I	9,400	11,750	23,500
8"	08CHS2X	*	I	08CHSP2X	*	I	18,200	22,750	45,500
8"	08CHS4X	*	I	08CHSP4X	*	I	35,200	45,500	91,000
10"	10CHS1X	*	I	10CHSP1X	*	I	11,760	14,700	29,400
10"	10CHS2X	*	I	10CHSP2X	*	I	22,720	28,400	56,800
12"	12CHS1X	*	I	12CHSP1X	*	I	14,120	17,600	35,300
12"	12CHS2X	*	I	12CHSP2X	*	I	27,280	34,100	68,200

Note:

- See weights page for weights



BHS Type II

Nylon or polyester basket type web slings with alloy steel basket fittings

Features:

- Heavy duty 9800 lb. webbing with UV inhibitors
- Orange vinyl tag with clear vinyl cover to protect data
- Alloy steel end fittings
- 3-7% stretch with polyester
- 6-10% stretch with nylon
- Proof testing available upon request
- Design factor of 5 to 1

How to order:

- Combine model, length in feet, and type

WARNING

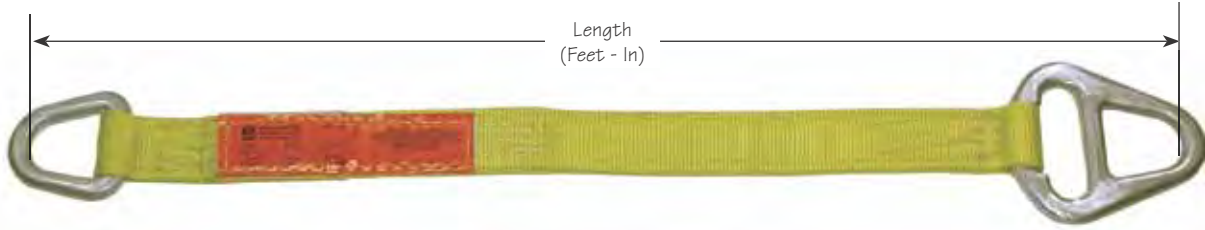
See web sling warnings page for warnings and inspection criteria

Width	Nylon Part Number			Polyester Part Number			Rated Capacities in Lbs.	
	Model	Length	Type	Model	Length	Type	Vertical	Basket
2"	02BHS1X	*	II	02BHS1PX	*	II	3,100	6,200
2"	02BHS2X	*	II	02BHS2PX	*	II	6,200	12,400
2"	02BHS4X	*	II	02BHS4PX	*	II	11,000	22,000
3"	03BHS1X	*	II	03BHS1PX	*	II	4,700	9,400
3"	03BHS2X	*	II	03BHS2PX	*	II	8,800	17,600
3"	03BHS4X	*	II	03BHS4PX	*	II	16,450	32,900
4"	04BHS1X	*	II	04BHS1PX	*	II	6,200	12,400
4"	04BHS2X	*	II	04BHS2PX	*	II	11,000	22,000
4"	04BHS4X	*	II	04BHS4PX	*	II	20,400	40,800
6"	06BHS1X	*	II	06BHS1PX	*	II	9,300	18,600
6"	06BHS2X	*	II	06BHS2PX	*	II	16,500	33,000
6"	06BHS4X	*	II	06BHS4PX	*	II	30,600	61,200
8"	08BHS1X	*	II	08BHS1PX	*	II	11,750	23,500
8"	08BHS2X	*	II	08BHS2PX	*	II	22,750	45,500
8"	08BHS4X	*	II	08BHS4PX	*	II	45,500	91,000
10"	10BHS1X	*	II	10BHS1PX	*	II	14,700	29,400
10"	10BHS2X	*	II	10BHS2PX	*	II	28,400	56,800
12"	12BHS1X	*	II	12BHS1PX	*	II	17,600	35,300
12"	12BHS2X	*	II	12BHS2PX	*	II	34,100	68,200

Note:

- See weights page for weights

WEB SLINGS



CHA Type I

Nylon or polyester web slings with combination choker/basket aluminum fittings

Features:

- Heavy duty 9800 lb. webbing with UV inhibitors
- Orange vinyl tag with clear vinyl cover to protect data
- Aluminum end fittings
- 3-7% stretch with polyester
- 6-10% stretch with nylon
- Proof testing available upon request
- Design factor of 5 to 1

How to order:

- Combine model, length in feet, and type



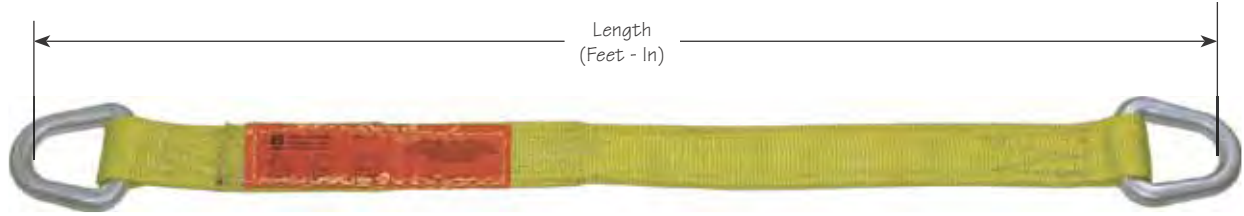
WARNING

See web sling warnings page for warnings and inspection criteria

Width	Nylon Part Number			Polyester Part Number			Capacities in Lbs.		
	Model	Length	Type	Model	Length	Type	Choker	Vertical	Basket
2"	02CHA1X	*	I	02CHA1PX	*	I	2480	3100	6200
3"	03CHA1X	*	I	03CHAP1X	*	I	3720	4700	9400
4"	04CHA1X	*	I	04CHA1PX	*	I	4960	6200	12400
6"	06CHA1X	*	I	06CHA1PX	*	I	7440	9300	18600

Note:

- See weights page for weights



BHA Type II

Nylon or polyester basket type web slings with aluminum basket fittings

Features:

- Heavy duty 9800 lb. webbing with UV inhibitors
- Orange vinyl tag with clear vinyl cover to protect data
- Aluminum end fittings
- 3-7% stretch with polyester
- 6-10% stretch with nylon
- Proof testing available upon request
- Design factor of 5 to 1

How to order:

- Combine model, length in feet, and type

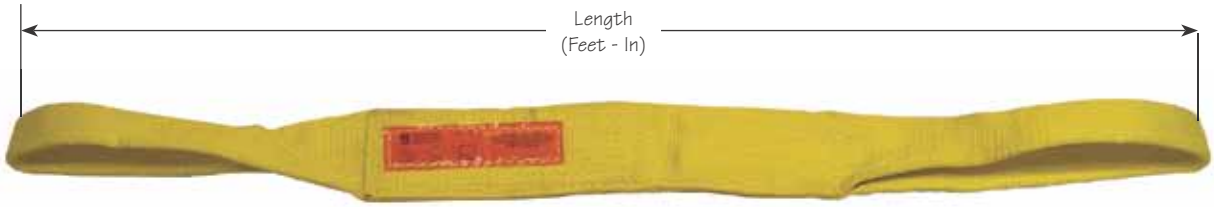
WARNING
See web sling warnings page for warnings and inspection criteria

Width	Nylon Part Number			Polyester Part Number			Rated Capacities in Lbs.	
	Model	Length	Type	Model	Length	Type	Vertical	Basket
2"	02BHA1X	*	II	02BHA1PX	*	II	3100	6200
3"	03BHA1X	*	II	03BHA1PX	*	II	4700	9400
4"	04BHA1X	*	II	04BHA1PX	*	II	6200	12400
6"	06BHA1X	*	II	06BHA1PX	*	II	9300	18600

Note:

- See weights page for weights

WEB SLINGS



EE Type III
Nylon web sling with flat eyes each end



EE Type IIIC
Nylon web sling with flat buffer web lined eyes each end

Features:

- Heavy duty nylon 9800 lb. webbing with UV inhibitors
- Orange vinyl tag with clear vinyl cover to protect data
- Extra eye protection available with buffer web lined eyes
- 6-10% stretch with nylon
- Proof testing available upon request
- Design factor of 5 to 1

How to order:

- Combine model, length in feet, and type

⚠ WARNING

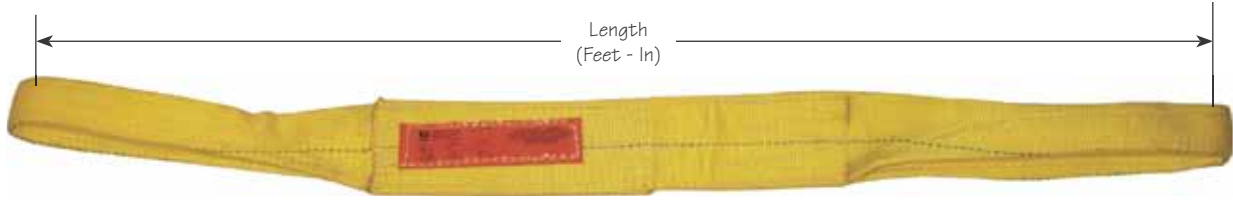
See web sling warnings page
for warnings and inspection criteria

Width	Part Number			Part Number w/ Buffer Web Lined Eyes			Eye Width	Eye Length	Rated Capacities in Pounds		
	Model	Length	Type	Model	Length	Type			Choker	Vertical	Basket
1"	01EE1X	*	III	01EE1X	*	IIIC	1"	9"	1,280	1,600	3,200
1"	01EE2X	*	III	01EE2X	*	IIIC	1"	9"	2,480	3,100	6,200
1"	01EE4X	*	III	01EE4X	*	IIIC	1"	12"	4,400	5,500	11,000
2"	02EE1X	*	III	02EE1X	*	IIIC	2"	9"	2,480	3,100	6,200
2"	02EE2X	*	III	02EE2X	*	IIIC	2"	9"	4,960	6,200	12,400
2"	02EE4X	*	III	02EE4X	*	IIIC	2"	12"	8,800	11,000	22,000
3"	03EE1X	*	III	03EE1X	*	IIIC	1-1/2"	9"	3,760	4,700	9,400
3"	03EE2X	*	III	03EE2X	*	IIIC	1-1/2"	12"	7,040	8,800	17,600
3"	03EE4X	*	III	03EE4X	*	IIIC	1-1/2"	18"	13,160	16,450	32,900
4"	04EE1X	*	III	04EE1X	*	IIIC	1-1/2"	12"	4,960	6,200	12,400
4"	04EE2X	*	III	04EE2X	*	IIIC	1-1/2"	12"	8,800	11,000	22,000
4"	04EE4X	*	III	04EE4X	*	IIIC	2"	18"	16,320	20,400	40,800
6"	06EE1X	*	III	06EE1X	*	IIIC	2"	14"	7,440	9,300	18,600
6"	06EE2X	*	III	06EE2X	*	IIIC	2"	14"	13,200	16,500	33,000
6"	06EE4X	*	III	06EE4X	*	IIIC	3"	20"	24,480	30,600	61,200
8"	08EE1X	*	III	08EE1X	*	IIIC	3"	18"	9,400	11,750	23,500
8"	08EE2X	*	III	08EE2X	*	IIIC	3"	18"	18,200	22,750	45,500
8"	08EE4X	*	III	08EE4X	*	IIIC	4"	24"	36,400	45,500	91,000
10"	10EE1X	*	III	10EE1X	*	IIIC	4"	22"	11,760	14,700	29,400
10"	10EE2X	*	III	10EE2X	*	IIIC	4"	22"	22,720	28,400	56,800
10"	10EE4X	*	III	10EE4X	*	IIIC	5"	28"	45,440	56,800	113,600
12"	12EE1X	*	III	12EE1X	*	IIIC	5"	26"	14,120	17,650	35,300
12"	12EE2X	*	III	12EE2X	*	IIIC	5"	26"	27,280	34,100	68,200
12"	12EE4X	*	III	12EE4X	*	IIIC	6"	32"	54,560	68,200	136,400

Note:

- See weights page for weights

WEB SLINGS



Model: EE Type III

Polyester web sling with flat eyes each end



EE Type IIIC

Polyester web sling with flat buffer web lined eyes each end

Features:

- Heavy duty polyester 9800 lb. webbing with UV inhibitors
- Orange vinyl tag with clear vinyl cover to protect data
- Extra eye protection available with buffer web lined eyes
- 3-7% stretch with polyester
- Proof testing available upon request
- Design factor of 5 to 1

How to order:

- Combine model, length in feet, and type

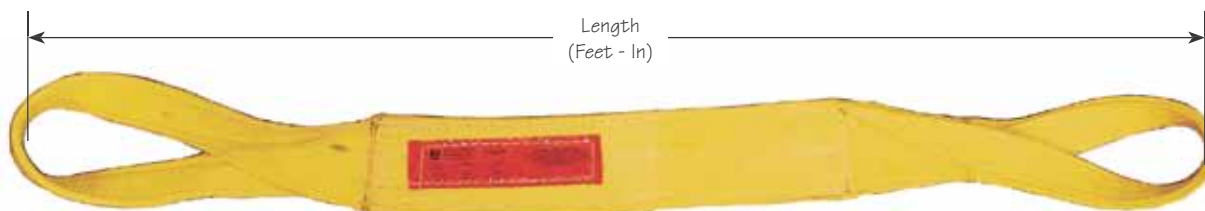
⚠ WARNING

See web sling warnings page for warnings and inspection criteria

Width	Part Number			Part Number w/ Buffer Web Lined Eyes			Eye Width	Eye Length	Rated Capacities in Pounds		
	Model	Length	Type	Model	Length	Type			Choker	Vertical	Basket
1"	01EE1PX	*	III	01EE1PX	*	IIIC	1"	9"	1,280	1,600	3,200
1"	01EE2PX	*	III	01EE2PX	*	IIIC	1"	9"	2,480	3,100	6,200
1"	01EE4PX	*	III	01EE4PX	*	IIIC	1"	12"	4,400	5,500	11,000
2"	02EE1PX	*	III	02EE1PX	*	IIIC	2"	9"	2,480	3,100	6,200
2"	02EE2PX	*	III	02EE2PX	*	IIIC	2"	9"	4,960	6,200	12,400
2"	02EE4PX	*	III	02EE4PX	*	IIIC	2"	12"	8,800	11,000	22,000
3"	03EE1PX	*	III	03EE1PX	*	IIIC	1-1/2"	9"	3,760	4,700	9,400
3"	03EE2PX	*	III	03EE2PX	*	IIIC	1-1/2"	12"	7,040	8,800	17,600
3"	03EE4PX	*	III	03EE4PX	*	IIIC	1-1/2"	18"	13,160	16,450	32,900
4"	04EE1PX	*	III	04EE1PX	*	IIIC	1-1/2"	12"	4,960	6,200	12,400
4"	04EE2PX	*	III	04EE2PX	*	IIIC	1-1/2"	12"	8,800	11,000	22,000
4"	04EE4PX	*	III	04EE4PX	*	IIIC	2"	18"	16,320	20,400	40,800
6"	06EE1PX	*	III	06EE1PX	*	IIIC	2"	14"	7,440	9,300	18,600
6"	06EE2PX	*	III	06EE2PX	*	IIIC	2"	14"	13,200	16,500	33,000
6"	06EE4PX	*	III	06EE4PX	*	IIIC	3"	20"	24,480	30,600	61,200
8"	08EE1PX	*	III	08EE1PX	*	IIIC	3"	18"	9,400	11,750	23,500
8"	08EE2PX	*	III	08EE2PX	*	IIIC	3"	18"	18,200	22,750	45,500
8"	08EE4PX	*	III	08EE4PX	*	IIIC	4"	24"	36,400	45,500	91,000
10"	10EE1PX	*	III	10EE1PX	*	IIIC	4"	22"	11,760	14,700	29,400
10"	10EE2PX	*	III	10EE2PX	*	IIIC	4"	22"	22,720	28,400	56,800
10"	10EE4PX	*	III	10EE4PX	*	IIIC	5"	28"	45,440	56,800	113,600
12"	12EE1PX	*	III	12EE1PX	*	IIIC	5"	26"	14,120	17,650	35,300
12"	12EE2PX	*	III	12EE2PX	*	IIIC	5"	26"	27,280	34,100	68,200
12"	12EE4PX	*	III	12EE4PX	*	IIIC	6"	32"	54,560	68,200	136,400

Note:

- See weights page for weights



EE Type IV

Nylon web sling with twisted eyes each end



EE Type IVC

Nylon web sling with twisted buffer web eyes each end

Features:

- Heavy Duty nylon 9800 lb. webbing with UV inhibitors
- Orange vinyl tag with clear vinyl cover to protect data
- Extra eye protection available with buffer web lined eyes
- 6-10% stretch with nylon
- Proof testing available upon request
- Design factor of 5 to 1

How to order:

- Combine model, length in feet, and type

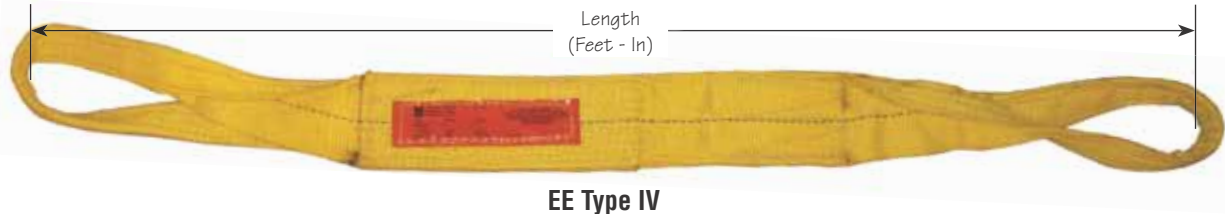
⚠ WARNING

See web sling warnings page
for warnings and inspection criteria

Width	Part Number			Part Number w/ Buffer Web Lined Eyes			Eye Width	Eye Length	Rated Capacities in Pounds		
	Model	Length	Type	Model	Length	Type			Choker	Vertical	Basket
1"	01EE1X	*	IV	01EE1X	*	IVC	1"	9"	1,280	1,600	3,200
1"	01EE2X	*	IV	01EE2X	*	IVC	1"	9"	2,480	3,100	6,200
1"	01EE4X	*	IV	01EE4X	*	IVC	1"	12"	4,400	5,500	11,000
2"	02EE1X	*	IV	02EE1X	*	IVC	2"	9"	2,480	3,100	6,200
2"	02EE2X	*	IV	02EE2X	*	IVC	2"	9"	4,960	6,200	12,400
2"	02EE4X	*	IV	02EE4X	*	IVC	2"	12"	8,800	11,000	22,000
3"	03EE1X	*	IV	03EE1X	*	IVC	1-1/2"	9"	3,760	4,700	9,400
3"	03EE2X	*	IV	03EE2X	*	IVC	1-1/2"	12"	7,040	8,800	17,600
3"	03EE4X	*	IV	03EE4X	*	IVC	1-1/2"	18"	13,160	16,450	32,900
4"	04EE1X	*	IV	04EE1X	*	IVC	1-1/2"	12"	4,960	6,200	12,400
4"	04EE2X	*	IV	04EE2X	*	IVC	1-1/2"	12"	8,800	11,000	22,000
4"	04EE4X	*	IV	04EE4X	*	IVC	2"	18"	16,320	20,400	40,800
6"	06EE1X	*	IV	06EE1X	*	IVC	2"	14"	7,440	9,300	18,600
6"	06EE2X	*	IV	06EE2X	*	IVC	2"	14"	13,200	16,500	33,000
6"	06EE4X	*	IV	06EE4X	*	IVC	3"	20"	24,480	30,600	61,200
8"	08EE1X	*	IV	08EE1X	*	IVC	3"	18"	9,400	11,750	23,500
8"	08EE2X	*	IV	08EE2X	*	IVC	3"	18"	18,200	22,750	45,500
8"	08EE4X	*	IV	08EE4X	*	IVC	4"	24"	36,400	45,500	91,000
10"	10EE1X	*	IV	10EE1X	*	IVC	4"	22"	11,760	14,700	29,400
10"	10EE2X	*	IV	10EE2X	*	IVC	4"	22"	22,720	28,400	56,800
10"	10EE4X	*	IV	10EE4X	*	IVC	5"	28"	45,440	56,800	113,600
12"	12EE1X	*	IV	12EE1X	*	IVC	5"	26"	14,120	17,650	35,300
12"	12EE2X	*	IV	12EE2X	*	IVC	5"	26"	27,280	34,100	68,200
12"	12EE4X	*	IV	12EE4X	*	IVC	6"	32"	54,560	68,200	136,400

Note:

- See weights page for weights



EE Type IV

Polyester web sling with twisted eyes each end



EE Type IVC

Polyester web sling with twisted buffer lined eyes each end

Features:

- Heavy duty polyester 9800 lb. webbing with UV inhibitors
- Orange vinyl tag with clear vinyl cover to protect data
- Extra eye protection available with buffer web lined eyes
- 3-7% stretch with polyester
- Proof testing available upon request
- Design factor of 5 to 1

How to order:

- Combine model, length in feet, and type

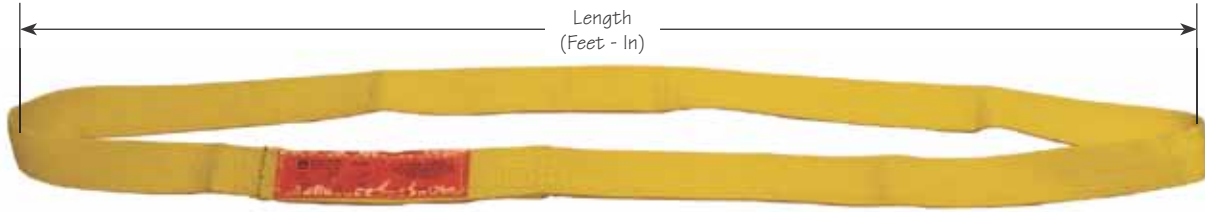
⚠ WARNING

See web sling warnings page
for warnings and inspection criteria

Width	Part Number			Part Number w/ Buffer Web Lined Eyes			Eye Width	Eye Length	Rated Capacities in Pounds		
	Model	Length	Type	Model	Length	Type			Choker	Vertical	Basket
1"	01EE1PX	*	IV	01EE1PX	*	IVC	1"	9"	1,280	1,600	3,200
1"	01EE2PX	*	IV	01EE2PX	*	IVC	1"	9"	2,480	3,100	6,200
1"	01EE4PX	*	IV	01EE4PX	*	IVC	1"	12"	4,400	5,500	11,000
2"	02EE1PX	*	IV	02EE1PX	*	IVC	2"	9"	2,480	3,100	6,200
2"	02EE2PX	*	IV	02EE2PX	*	IVC	2"	9"	4,960	6,200	12,400
2"	02EE4PX	*	IV	02EE4PX	*	IVC	2"	12"	8,800	11,000	22,000
3"	03EE1PX	*	IV	03EE1PX	*	IVC	1-1/2"	9"	3,760	4,700	9,400
3"	03EE2PX	*	IV	03EE2PX	*	IVC	1-1/2"	12"	7,040	8,800	17,600
3"	03EE4PX	*	IV	03EE4PX	*	IVC	1-1/2"	18"	13,160	16,450	32,900
4"	04EE1PX	*	IV	04EE1PX	*	IVC	1-1/2"	12"	4,960	6,200	12,400
4"	04EE2PX	*	IV	04EE2PX	*	IVC	1-1/2"	12"	8,800	11,000	22,000
4"	04EE4PX	*	IV	04EE4PX	*	IVC	2"	18"	16,320	20,400	40,800
6"	06EE1PX	*	IV	06EE1PX	*	IVC	2"	14"	7,440	9,300	18,600
6"	06EE2PX	*	IV	06EE2PX	*	IVC	2"	14"	13,200	16,500	33,000
6"	06EE4PX	*	IV	06EE4PX	*	IVC	3"	20"	24,480	30,600	61,200
8"	08EE1PX	*	IV	08EE1PX	*	IVC	3"	18"	9,400	11,750	23,500
8"	08EE2PX	*	IV	08EE2PX	*	IVC	3"	18"	18,200	22,750	45,500
8"	08EE4PX	*	IV	08EE4PX	*	IVC	4"	24"	36,400	45,500	91,000
10"	10EE1PX	*	IV	10EE1PX	*	IVC	4"	22"	11,760	14,700	29,400
10"	10EE2PX	*	IV	10EE2PX	*	IVC	4"	22"	22,720	28,400	56,800
10"	10EE4PX	*	IV	10EE4PX	*	IVC	5"	28"	45,440	56,800	113,600
12"	12EE1PX	*	IV	12EE1PX	*	IVC	5"	26"	14,120	17,650	35,300
12"	12EE2PX	*	IV	12EE2PX	*	IVC	5"	26"	27,280	34,100	68,200
12"	12EE4PX	*	IV	12EE4PX	*	IVC	6"	32"	54,560	68,200	136,400

Note:

- See weights page for weights



EN Type V
Nylon endless web sling

Features:

- Heavy duty nylon 9800 lb. webbing with UV inhibitors
- Orange vinyl tag with clear vinyl cover to protect data
- More stability when choked
- 6-10% stretch with nylon
- Proof testing available upon request
- Design factor of 5 to 1

How to order:

- Combine model, length in feet, and type

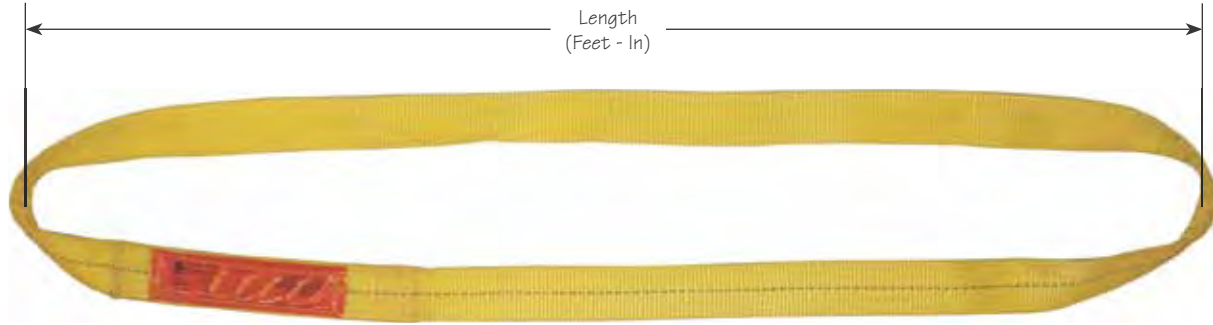
⚠ WARNING

See web sling warnings page
for warnings and inspection criteria

Width	Part Number			Rated Capacities in Pounds		
	Model	Length	Type	Choker	Vertical	Basket
1"	01EN1X	*	V	2,560	3,200	6,400
1"	01EN2X	*	V	4,960	6,200	12,400
2"	02EN1X	*	V	4,960	6,200	12,400
2"	02EN2X	*	V	9,920	12,400	24,800
3"	03EN1X	*	V	7,520	9,400	18,800
3"	03EN2X	*	V	14,080	17,600	35,200
4"	04EN1X	*	V	9,920	12,400	24,800
4"	04EN2X	*	V	17,600	22,000	44,000
6"	06EN1X	*	V	14,880	18,600	37,200
6"	06EN2X	*	V	26,400	33,000	66,000

Note:

- See weights page for weights



EN Type V
Polyester endless web sling

Features:

- Heavy duty polyester 9800 lb. webbing with UV inhibitors
- Orange vinyl tag with clear vinyl cover to protect data
- More stability when choked
- 3-7% stretch with polyester
- Proof testing available upon request
- Design factor of 5 to 1

How to order:

- Combine model, length in feet, and type

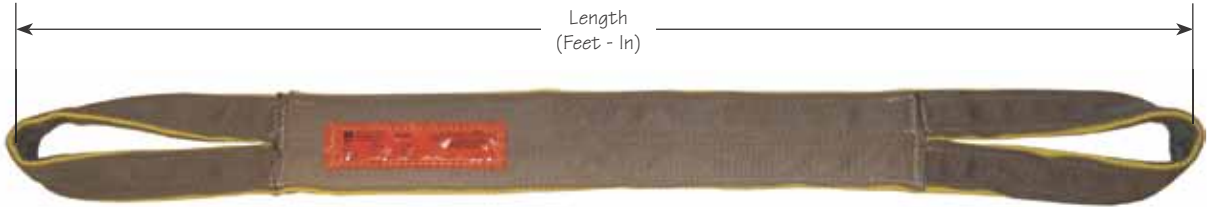
WARNING
See web sling warnings page
for warnings and inspection criteria

Width	Part Number			Rated Capacities in Pounds		
	Model	Length	Type	Choker	Vertical	Basket
1"	01EN1PX	*	V	2560	3200	6400
1"	01EN2PX	*	V	4960	6200	12400
2"	02EN1PX	*	V	4960	6200	12400
2"	02EN2PX	*	V	9920	12400	24800
3"	03EN1PX	*	V	7440	9300	18600
3"	03EN2PX	*	V	14880	18600	37200
4"	04EN1PX	*	V	9920	12400	24800
4"	04EN2PX	*	V	17600	22000	44000
6"	06EN1PX	*	V	14880	18600	37200
6"	06EN2PX	*	V	26400	33000	66000

Note:

- See weights page for weights

WEB SLINGS



RE Type VI

Nylon reversed eye sling with buffer web wear pad in body and in each eye

Features

- Heavy duty nylon 9800 lb. webbing with UV inhibitors
- Orange vinyl tag with clear vinyl cover to protect data
- Buffer web wear pad both sides of the entire length of body for abrasion resistance
- 6-10% stretch with nylon
- Proof testing available upon request
- Design factor of 5 to 1

How to order:

- Combine model, length in feet, and type

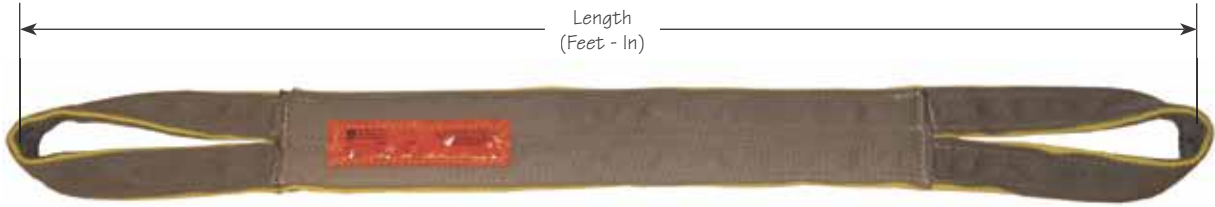
WARNING
See web sling warnings page for warnings and inspection criteria

Body Width	Part Number			Eye Width	Eye Length	Rated Capacities in Pounds		
	Model	Length	Type			Choker	Vertical	Basket
2"	01RE1X	*	VI	1"	9"	2,560	3,200	6,400
2"	01RE2X	*	VI	1"	12"	4,960	6,200	12,400
4"	02RE1X	*	VI	1"	12"	4,960	6,200	12,400
4"	02RE2X	*	VI	2"	18"	9,920	12,400	24,800
4"	02RE3X	*	VI	2"	18"	13,700	17,200	34,400
4"	02RE4X	*	VI	2"	18"	17,600	22,000	44,000
6"	03RE1X	*	VI	1-1/2"	14"	7,520	9,400	18,800
6"	03RE2X	*	VI	1-1/2"	18"	14,080	17,600	35,200
6"	03RE3X	*	VI	3"	20"	20,200	25,200	50,500
6"	03RE4X	*	VI	3"	24"	26,320	32,900	65,800

Note:

- See weights page for weights

WEB SLINGS



RE Type VI

Polyester reversed eye sling with buffer web wear pad in body and in each eye

Features:

- Heavy duty polyester on 9800 lb. webbing with UV inhibitors
- Orange vinyl tag with clear vinyl cover to protect data
- Buffer web wear pad both sides of the entire length of body for abrasion resistance
- 3-7% stretch with polyester
- Proof testing available upon request
- Design factor of 5 to 1

How to order:

- Combine model, length in feet, and type

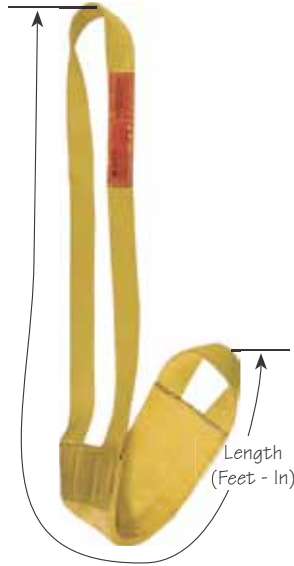
WARNING
See web sling warnings page for warnings and inspection criteria

Body Width	Part Number			Eye Width	Eye Length	Rated Capacities in Pounds		
	Model	Length	Type			Choker	Vertical	Basket
2"	01RE1PX	*	VI	1"	9"	2,560	3,200	6,400
2"	01RE2PX	*	VI	1"	12"	4,960	6,200	12,400
4"	02RE1PX	*	VI	1"	12"	4,960	6,200	12,400
4"	02RE2PX	*	VI	2"	18"	9,920	12,400	24,800
4"	02RE3PX	*	VI	2"	18"	13,700	17,200	34,400
4"	02RE4PX	*	VI	2"	18"	17,600	22,000	44,000
6"	03RE1PX	*	VI	1-1/2"	14"	7,520	9,400	18,800
6"	03RE2PX	*	VI	1-1/2"	18"	14,080	17,600	35,200
6"	03RE3PX	*	VI	3"	20"	20,200	25,200	50,500
6"	03RE4PX	*	VI	3"	24"	26,320	32,900	65,800

Note:

- See weights page for weights

WEB SLINGS



HH
Hose handling slings

Features:

- Heavy duty 9800 lb. webbing with UV inhibitors
- Orange vinyl tag with clear vinyl cover to protect data
- Specifically designed to handle hoses
- 6-10% Stretch with nylon
- Proof testing available upon request
- Design factor of 5 to 1

How to order:

- Specify model

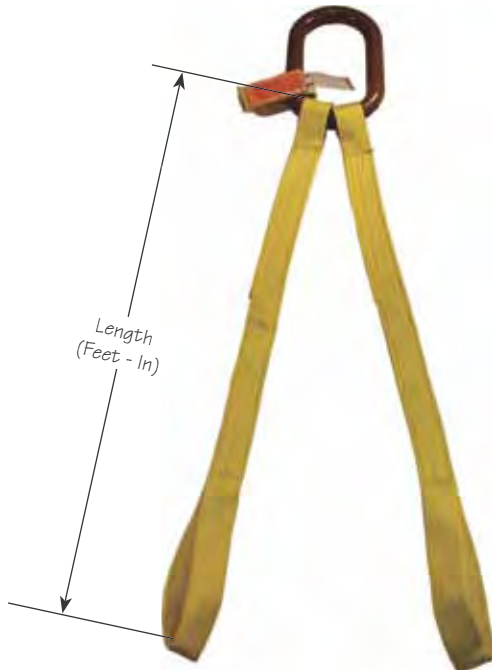
WARNING

See web sling warnings page for warnings and inspection criteria

Hose Dia.	Nylon Model	Polyester Model	Sling Width	Sling Length	Choker Rated Capacity (lbs)
4"	HH1-94	HH1-94P	4"	3'6"	3,000
6"	HH1-96	HH1-96P	6"	4'6"	4,000
8"	HH1-98	HH1-98P	8"	6'	5,000
10"	HH1-910	HH1-910P	10"	9'	6,000
12"	HH1-912	HH1-912P	12"	11'	7,000
16"	HH2-916	HH2-916P	16"	14'	10,000

Note:

- See weights page for weights
- The hose handling sling is used in the handling of hoses and is designed to prevent crushing, kinking and cutting of hoses by evenly distributing the load over the width of the sling webbing
- Hose handling slings are designed to be used in choker hitch only



2B-MEE

2 leg nylon web bridle with master link and standard eyes



2B-MHH

2 leg nylon web bridle with master link and web hooks

Features:

- Heavy duty nylon 9800 lb. webbing with UV inhibitors
- Orange vinyl tag with clear vinyl cover to protect data
- Alloy master link with 45° indicator marks
- Standard eyes or WS-320 web hooks on bottom
- 6-10% stretch with nylon
- Proof testing available upon request
- Design factor of 5 to 1

How to order:

- Combine model, length in feet, and type

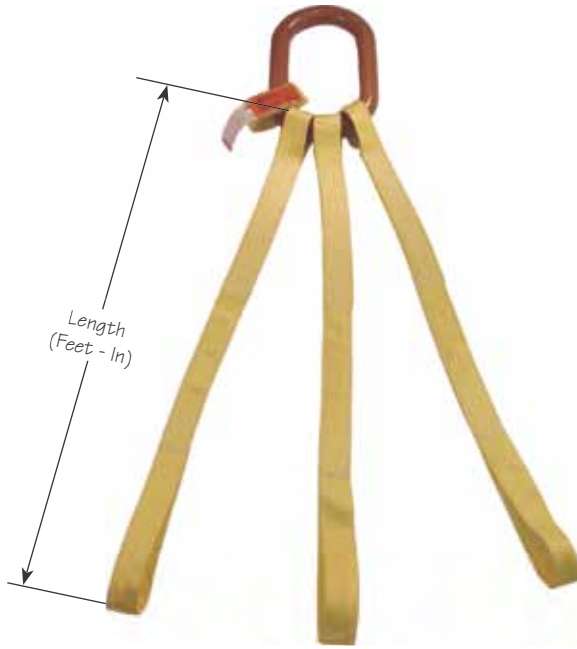
WARNING

See web sling warnings page for warnings and inspection criteria

Width	Part Number			Part Number			Master Link Size	WS-320 Web Hook Size	Rated Capacities in Pounds		
	Model w/ Eyes only	Length	Type	Model w/ Hooks	Length	Type			60°	45°	30°
1"	2B01EE1X	*	MEE	2B01EE1X	*	MHH	3/4"	1"	2,800	2,300	1,600
1"	2B01EE2X	*	MEE	2B01EE2X	*	MHH	3/4"	1"	5,400	4,400	3,100
2"	2B02EE1X	*	MEE	2B02EE1X	*	MHH	1"	2"	5,400	4,400	3,100
2"	2B02EE2X	*	MEE	2B02EE2X	*	MHH	1"	2"	10,700	8,800	6,200
3"	2B03EE1X	*	MEE	2B03EE1X	*	MHH	1-1/4"	3"	8,100	6,600	4,700
3"	2B03EE2X	*	MEE	2B03EE2X	*	MHH	1-1/4"	3"	15,200	12,400	8,800

Note:

- Rated capacity based on both legs carrying the load equally
- See weights page for weights



3B-MEE

3 leg nylon web bridle with master link and standard eyes



3B-MHH

3 leg nylon web bridle with master link and web hooks

Features:

- Heavy duty nylon 9800 lb. webbing with UV inhibitors
- Orange vinyl tag with clear vinyl cover to protect data
- Alloy master link with 45° indicator marks
- Standard eyes or WS-320 web hooks on bottom
- 6-10% stretch with nylon
- Proof testing available upon request
- Design factor of 5 to 1

How to order:

- Combine model, length in feet, and type

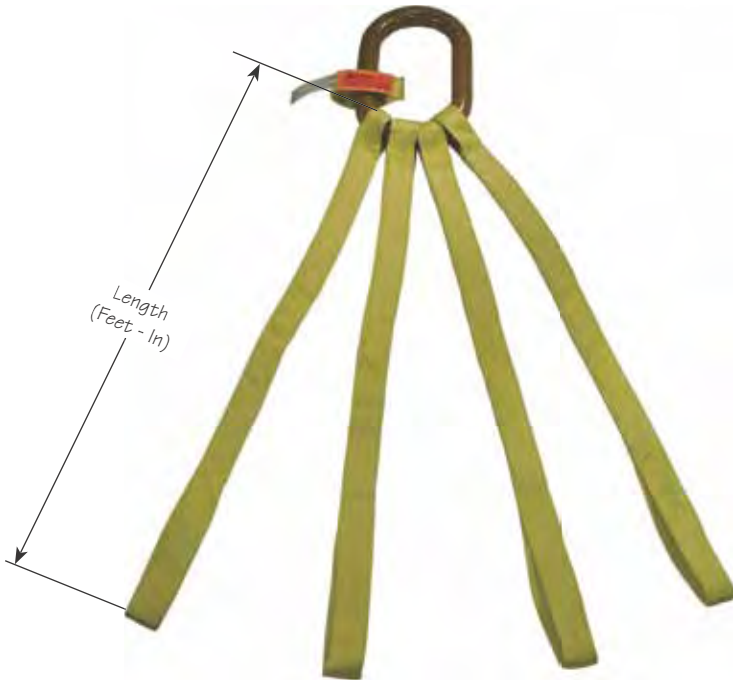
WARNING

See web sling warnings page for warnings and inspection criteria

Width	Part Number			Part Number			Master Link Size	WS-320 Web Hook Size	Rated Capacities in Pounds		
	Model w/ Eyes only	Length	Type	Model w/ Hooks	Length	Type			60°	45°	30°
1"	3B01EE1X	*	MEE	3B01EE1X	*	MHH	1"	1"	4,100	3,300	2,400
1"	3B01EE2X	*	MEE	3B01EE2X	*	MHH	1"	1"	8,000	6,500	4,600
2"	3B02EE1X	*	MEE	3B02EE1X	*	MHH	1-1/4"	2"	8,000	6,500	4,600
2"	3B02EE2X	*	MEE	3B02EE2X	*	MHH	1-1/4"	2"	16,100	13,100	9,300
3"	3B03EE1X	*	MEE	3B03EE1X	*	MHH	1-1/2"	3"	12,200	9,900	7,000
3"	3B03EE2X	*	MEE	3B03EE2X	*	MHH	1-1/2"	3"	22,800	18,600	13,200

Note:

- Rated capacity based on all three legs carrying the load equally
- See weights page for weights



4B-MEE

4 leg nylon web bridle with master link and standard eyes



4B-MHH

4 leg nylon web bridle with master link and web hooks

Features:

- Heavy duty nylon 9800 lb. webbing with UV inhibitors
- Orange vinyl tag with clear vinyl cover to protect data
- Alloy master link with 45° indicator marks
- Standard eyes or WS-320 web hooks on bottom
- 6-10% stretch with nylon
- Proof testing available upon request
- Design factor of 5 to 1

How to order:

- Combine model, length in feet, and type

WARNING

See web sling warnings page for warnings and inspection criteria

Width	Part Number			Part Number			Master Link Size	WS-320 Web Hook Size	Rated Capacities in Pounds		
	Model w/ Eyes only	Length	Type	Model w/ Hooks	Length	Type			60°	45°	30°
1"	4B01EE1X	*	MEE	4B01EE1X	*	MHH	1-1/4"	1"	5,500	4,500	3,200
1"	4B01EE2X	*	MEE	4B01EE2X	*	MHH	1-1/4"	1"	10,700	8,700	6,200
2"	4B02EE1X	*	MEE	4B02EE1X	*	MHH	1-1/2"	2"	10,700	8,700	6,200
2"	4B02EE2X	*	MEE	4B02EE2X	*	MHH	1-1/2"	2"	21,400	17,500	12,400
3"	4B03EE1X	*	MEE	4B03EE1X	*	MHH	1-3/4"	3"	16,200	13,200	9,400
3"	4B03EE2X	*	MEE	4B03EE2X	*	MHH	1-3/4"	3"	30,400	24,800	17,600

Note:

- Rated capacity based on all four legs carrying the load equally
- See weights page for weights

Web Sling Protection

Wear Pads

Web Slings can be damaged, abraded, punctured, or cut in use if not protected. Be sure to protect you slings against the following:

- Load Edges
- Jagged materials
- Abrasion surfaces
- Burred hooks

There is no such thing as “Cut Proof” protection. Some materials are better for abrasion, and others are better against the effects of cutting. Select the Protection material best suited on your application.

Available Materials: Buffer web nylon, heavy duty webbing, leather, neoprene, white felt, barrier webbing, and aramid webbing. Protection can be made of multiple layers and blended materials.



WP
Wear pad

Features:

- Protects the sling body from abrasion
- Heavy duty gray buffer webbing standard
- Sewn on one side or both sides of the sling
- Can be positioned in a specific location
- Can span the entire length of the body or just a linear portion of the sling body

How to order:

- When ordering a web sling, add the wear pad model and description to your inquiry



EW
Edge wrap

Features:

- Protects the sling edges from abrasion
- Heavy duty gray buffer webbing standard
- Sewn on both sides the entire length of the sling

How to order:

- When ordering a web sling, add the wear pad model and description to your inquiry



BW
Body wrap

Features:

- Protects the edges and the sling body from abrasion
- Heavy duty gray buffer webbing standard
- Sewn completely around the sling
- Can be positioned in a specific location in the sling body
- Can span the entire length of the body or just a linear portion of the sling body

How to order:

- When ordering a web sling, add the wear pad model and description to your inquiry

SWC1

Sliding Sleeve, 1 ply heavy duty nylon webbing both sides, sewn both sides with ends open

SWC2

Sliding Sleeve, 2 ply heavy duty nylon webbing both sides, sewn both sides with ends open

Features:

- Protects the sling from localized abrasion
- Heavy duty nylon webbing
- Sewn both sides
- Can slide on the sling and be positioned in a specific location

How to order:

- Combine model and length



Part Number – 1 ply		Width	Sling Width
Model	Length		
03SWC1	*	3"	1"
04SWC1	*	4"	2"
06SWC1	*	6"	3"
08SWC1	*	8"	4"
10SWC1	*	10"	6"
12SWC1	*	12"	8"
16SWC1	*	16"	10-12"
Part Number – 2 ply			
03SWC2	*	3"	1"
04SWC2	*	4"	2"
06SWC2	*	6"	3"
08SWC2	*	8"	4"
10SWC2	*	10"	6"
12SWC2	*	12"	8"
16SWC2	*	16"	10-12"

SBV2

Sliding Sleeve, 2 ply, heavy duty web inner plies, buffer webbing outer plies, sewn closed one side with Velcro closure other side

Features:

- Protects the sling from localized abrasion
- Heavy duty nylon and buffer webbing
- Easily attached and removed with the Velcro closure
- Can slide on the sling and be positioned in a specific location

How to order:

- Combine model and length



Part Number		Width	Sling Width
Model	Length		
03SBV2	*	3"	1"
04SBV2	*	4"	2"
06SBV2	*	6"	3"
08SBV2	*	8"	4"
10SBV2	*	10"	6"
12SBV2	*	12"	8"
16SBV2	*	16"	10-12"

WEB SLINGS

Model: SFV1

Sliding Sleeve, 1 ply, white felt sewn closed one side with Velcro closure other side.

Features:

- Protects the sling from localized abrasion
- Heavy duty 3/8" thick white felt
- Easily attached and removed with the Velcro closure
- Can slide on the sling and be positioned in a specific location
- Larger widths available upon request

How to order:

- Combine model and length



Part Number		Width	Sling Width
Model	Length		
03SFV1	*	3"	1"
04SFV1	*	4"	2"
06SFV1	*	6"	3"
08SFV1	*	8"	4"
10SFV1	*	10"	6"
12SFV1	*	12"	8"
16SFV1	*	16"	10-12"

Model: SFV2

Sliding Sleeve, 2 ply, nylon web inner lined with white felt outer layers, sewn closed one side with Velcro closure other side.

Features:

- Protects the sling from localized abrasion
- Heavy duty nylon webbing and 3/8" thick white felt
- Easily attached and removed with the Velcro closure
- Can slide on the sling and be positioned in a specific location
- Larger widths available upon request

How to order:

- Combine model and length



Part Number		Width	Sling Width
Model	Length		
03SFV2	*	3"	1"
04SFV2	*	4"	2"
06SFV2	*	6"	3"
08SFV2	*	8"	4"
10SFV2	*	10"	6"
12SFV2	*	12"	8"
16SFV2	*	16"	10-12"

Synthetic Armor Pads protect the slings from abrasion damage which can be caused by contact with rough surfaces such as concrete beams and structures. They are also used to protect finished or painted loads from marring. These wear pads can be made to fit any length or width sling. They can also be made in long lengths which the customer can cut into suitable sizes on the job. Double or triple thickness provides resistance for the more severe conditions. There is no maximum width and a variety of materials are used to protect slings and to protect loads.

SYNARM-SL – Synthetic Armor Pads

Sliding type, 2 ply heavy duty tubing both sides, filled with white felt, with ends open

Features:

- Protects the sling from localized abrasion
- Extra Heavy duty Covermax® tubing
- 3/8" high density white felt filled both sides
- Can slide on the sling and be positioned in a specific location

How to order:

- Combine model and length



Part Number		Width	Sling Width
Model	Length		
03SYNARM-SL	*	3"	1"
04SYNARM-SL	*	4"	2"
06SYNARM-SL	*	6"	3"
08SYNARM-SL	*	8"	4"
10SYNARM-SL	*	10"	6"
12SYNARM-SL	*	12"	8"

SYNARM-RM – Synthetic Armor Pad

Removable type, 2 ply tubing both sides, filled with white felt, with Velcro closure one side

Features:

- Protects the sling from localized abrasion
- Extra Heavy duty Covermax® tubing
- 3/8" high density white felt filled both sides
- Easily attached and removed with the Velcro closure
- Can slide on the sling and be positioned in a specific location
- Larger widths available upon request

How to order:

- Combine model and length



Part Number		Width	Sling Width
Model	Length		
03SYNARM-RM	*	3"	1"
04SYNARM-RM	*	4"	2"
06SYNARM-RM	*	6"	3"
08SYNARM-RM	*	8"	4"
10SYNARM-RM	*	10"	6"
12SYNARM-RM	*	12"	8"

SYNARM-EE – Synthetic Armor Pad

Eye and eye type, 2 ply tubing both sides, filled with white felt, with installation and removal handles each end.

Features:

- Fits over sling for maximum body protection
- Protects the sling from localized abrasion
- Extra Heavy duty Covermax® tubing
- 3/8" high density white felt filled both sides
- Handle sewn each end
- Larger widths available upon request

How to order:

- Combine model and length



Part Number		Width	Sling Width
Model	Length		
03SYNARM-EE	*	3"	1"
04SYNARM-EE	*	4"	2"
06SYNARM-EE	*	6"	3"
08SYNARM-EE	*	8"	4"
10SYNARM-EE	*	10"	6"
12SYNARM-EE	*	12"	8"

WEB SLINGS



CRNMX – CornerMax™ Pad

Edge protection, 1 ply web filled with 3/4" nylon rods, with 2 Velcro closures

Features:

- CornerMax™ Pad forms a tunnel between the load edge and the pad
- Position on corners or edges of the load
- Pad protects sling because of zero contact
- Filled with 3/4" nylon round bars
- Easily attached and removed with the Velcro closure
- Custom widths and sizes available upon request

How to order:

- Specify part number









Part Number	Width	Sling Width
CRNMX02	4"	Up to 2"
CRNMX03	5"	3"
CRNMX04	6"	4"
CRNMX05	8"	5"
CRNMX06	8"	6"
CRNMX08	10"	8"
CRNMX10	12"	10"



WEB SLINGS

⚠ WEB SLING WARNINGS

When inspecting a web sling, it shall be taken out of service immediately and returned for repair or replacement when any of the below defects are present.

Missing or illegible sling identification (tag)	
Acid or caustic burn	
Melting or charring of any part of the sling	
Holes, tears, cuts, abrasive wear, or snags that expose core yarns	
Broken or worn stitching in load bearing splices	
Excessive abrasive wear	
Knots in any part of the sling	
Discoloration and brittle or stiff areas on any part of the sling, which may mean chemical or ultraviolet/sunlight damage	

Fittings that are pitted, corroded, cracked, bent, twisted, gouged, or broken	
Damaged hooks per ASME B30.10	
Damaged rigging hardware per ASME B30.26	

and... Any condition that causes doubt about the continued use of the sling

Synthetic Web Slings Identification, Inspection, Rigging Practices

Synthetic Web Slings are designed and built to be easy to use and versatile. As with any quality product certain precautions and standards of treatment should be observed. Proper care will extend the useful life of synthetic web slings.

Follow the Guidelines set forth in ASME B30.9 "Slings" standard, OSHA 1910.184 and 1926.251.

Sling Identification

Each sling shall be marked to show the following:

- Name or Trademark of manufacturer
- Manufacturer's code or stock number
- Rated loads for the type(s) of hitch(es) used and the angle upon which it is based
- Type of synthetic web material
- Number of legs, if more than one

Sling identification shall be done by the sling manufacturer, and should be maintained by the user so as to be legible during the life of the sling.

Inspection

Synthetic Web Sling inspection falls into 3 categories. Initial, Frequent, and Periodic.

- **Initial Inspection**– Prior to use, all new, altered, modified, or repaired slings shall be inspected by a designated person to verify compliance
- **Frequent Inspection**
 - o A visual inspection for damage shall be performed by the user or other designated person each day or shift the sling is used
 - o Conditions such as those listed in the removal criteria section or any other condition that may result in a hazard shall not be returned to service until approved by a qualified person
 - o Written records are not required for frequent inspections
- **Periodic Inspections**
 - o A complete inspection for damage to the sling shall be periodically performed by a designated person. Inspection shall be conducted on the entire length including splices, end attachments, and fittings. The sling shall be examined for conditions such as those listed in the removal criteria section and a determination made as to whether they constitute a hazard
 - o Periodic Inspection Frequency – Periodic inspection intervals shall not exceed 1 year. The frequency of periodic inspections should be based on:
 - Frequency of sling use
 - Severity of service condition
 - Nature of lifts being made
 - Experience gained on the service life of slings used in similar circumstances
 - o Guidelines for time intervals
 - Normal service – yearly
 - Severe service – monthly to quarterly
 - Special service – as recommended by a qualified person
 - o A written record of the most recent periodic inspection shall be maintained

Removal Criteria

A synthetic web sling shall be removed from service if the following conditions are present.

- Missing or illegible sling identification (tag or markings)
- Acid or caustic burns
- Melting or charring of any part of the sling
- Holes, tears, cuts, or snags
- Broken or worn stitching in load bearing splices
- Excessive abrasive wear
- Knots in any part of the sling
- Discoloration and brittle or stiff areas on any part of the sling, which may mean chemical or ultraviolet/sunlight damage
- Fittings that are pitted, corroded, cracked, bent, twisted, gouged, or broken
- Damaged hooks, removal criteria as stated in ASME B30.10
- Damaged rigging hardware, removal criteria as stated in ASME B30.26
- Other conditions, including visible damage, that cause doubt as to the continued use of the sling

Rigging Practices

- Slings shall be shortened or adjusted only by methods approved by the sling manufacturer or a qualified person
- Slings shall not be shortened or lengthened by knotting or twisting
- The sling shall be hitched in a manner providing control of the load
- Slings in contact with edges, corners, or protrusions should be protected with a material of sufficient strength, thickness, and construction to prevent damage to the sling
- Shock loading should be avoided
- Loads should not be rested on the sling
- Slings should not be pulled from under the load when the load is resting in the sling
- Twisting shall be avoided
- During lifting, with or without load, personnel shall be alert for possible snagging
- When using multiple basket or choker hitches, the load should be rigged to prevent the sling from slipping or sliding along the load
- When using a basket hitch, the legs of the sling should contain or support the load from the sides, above the center of gravity, so that the load remains under control
- Slings should not be dragged on the floor or over an abrasive surface
- In a choker hitch, the choke point should only be on the sling body, not on a splice or fitting
- Slings should not be constricted, bunched or pinched by the load, hook, or any fitting
- The load applied to the hook should be centered in the base (bowl) of the hook to prevent point loading on the hook, unless the hook is designed for point loading
- An object in the eye of a sling should not be wider than one half the length of the eye

Environmental Considerations

- Temperature
 - o Polyester and nylon webbing slings shall not be used in contact with an object or at temperatures in excess of 194°F (90°C) or below (-40°C)
- Chemically Active Environments
 - o The strength of synthetic web slings can be degraded by chemically active environments. This includes exposure to chemicals in the form of solids, liquids, gases, vapors, or fumes. The sling manufacturer or qualified person should be consulted before slings are used in chemically active environments
- Sunlight and Ultraviolet Light
 - o The strength of synthetic webbing slings is degraded by exposure to sunlight and ultraviolet light. The sling manufacturer or qualified person should be consulted for additional retirement or inspection requirements. For additional information, see WSTDA-UV-Sling-2003

Sources:

ASME B30.9 "Slings" Standard
WSTDA "Web Sling and Tie-Down Association"
OSHA 1910.184 "Slings"
OSHA 1926.251 "Rigging Equipment for material handling"

How to Order Synthetic Web Slings and Technical Information

Determine the material the sling will be made from (nylon or polyester) based upon the environmental conditions to which it will be subjected

	Nylon	Polyester
Acid	NO	*
Alcohol	NO	OK
Aldehydes	OK	NO
Strong Alkalies	**	**
Bleaching Agents	NO	OK
Dry Cleaning Solvents	OK	OK
Ethers	OK	NO
Halogenated Hydrocarbons	OK	OK
Hydrocarbons	OK	OK
Keytones	OK	OK
Oil, Crude	OK	OK
Oil, Lubricating	OK	OK
Soaps, Detergents	OK	OK
Water, Seawater	OK	OK
Weak Alkalies	OK	OK

* Disintegrated by concentrated acid

** Degraded by strong alkalies at elevated temperatures

Web Elasticity –Stretch characteristics of web slings varies

Nylon: 6-10%

Polyester: 3-7%

Roundslings Elasticity – Stretch characteristics of roundslings varies.

Polyester: 3-5%

K-Spec: 1%

Operating Temperatures – Never exceed the temperatures listed below

Nylon: above 194°F (90°C) or below -40°F(-40°C)

Polyester: above 194°F (90°C) or below -40°F(-40°C)

K-Spec: above 180°F (82°C) or below -40°F(-40°C)

Proof Testing – All synthetic slings when required shall be proof tested to 2 times of the Rated Vertical Capacity as described in ASME B30.9. Slings shall be tested on a calibrated testing machine as described in ASME E-4

CHS - Web Sling w/ steel choker & triangle combination			
Width	Model	3' base	adder per foot
2"	02CHS1	3.46	0.092
2"	02CHS2	3.67	0.183
2"	02CHS4	17.77	0.367
3"	03CHS1	5.2	0.141
3"	03CHS2	5.53	0.282
3"	03CHS4	26.71	0.564
4"	04CHS1	9.63	0.019
4"	04CHS2	10.06	0.373
4"	04CHS4	47.14	0.746
6"	06CHS1	16.77	0.333
6"	06CHS2	17.53	0.667
6"	06CHS4	67.65	1.334
8"	08CHS1	38.19	0.439
8"	08CHS2	39.2	0.878
8"	08CHS4	92.25	1.756
10"	10CHS1	47.73	0.545
10"	10CHS2	48.98	1.091
10"	10CHS4	116.36	2.181
12"	12CHS1	62.31	0.662
12"	12CHS2	63.84	1.325
12"	12CHS4	78	2.65



BHS - Web Sling w/ steel triangle each end			
Width	Model	3' base	adder per foot
2"	02BHS1	2.46	0.092
2"	02BHS2	2.67	0.183
2"	02BHS4	3.94	0.367
3"	03BHS1	3.9	0.141
3"	03BHS2	4.23	0.282
3"	03BHS4	8.06	0.564
4"	04BHS1	6.33	0.019
4"	04BHS2	6.76	0.373
4"	04BHS4	11.72	0.746
6"	06BHS1	12.27	0.333
6"	06BHS2	13.03	0.667
6"	06BHS4	22.87	1.334
8"	08BHS1	26.19	0.439
8"	08BHS2	27.2	0.878
8"	08BHS4	34.41	1.756
10"	10BHS1	36.73	0.545
10"	10BHS2	37.98	1.091
10"	10BHS4	45.96	2.181
12"	12BHS1	41.31	0.662
12"	12BHS2	42.84	1.325
12"	12BHS4	61.67	2.65



CHA - Web Sling w/ aluminum choker & triangle combination			
Width	Model	3' base	adder per foot
2"	02CHA1	1.5	0.092
3"	03CHA1	2.75	0.141
4"	04CHA1	3.93	0.187
6"	06CHA1	9.47	0.333



BHA - Web Sling w/ aluminum triangle each end			
Width	Model	3' base	adder per foot
2"	02BHA1	1.08	0.092
3"	03BHA1	2.2	0.141
4"	04BHA1	3.13	0.187
6"	06BHA1	7.07	0.333



EE - Web Slings w/ standard eye each end			
Width	Model	3' base	adder per foot
1"	01EE1	0.3	0.046
1"	01EE2	0.34	0.092
1"	01EE4	0.68	0.185
2"	02EE1	0.6	0.092
2"	02EE2	0.68	0.183
2"	02EE4	1.36	0.367
3"	03EE1	0.92	0.141
3"	03EE2	1.04	0.282
3"	03EE4	2.09	0.564
4"	04EE1	1.21	0.187
4"	04EE2	1.38	0.373
4"	04EE4	2.76	0.746
6"	06EE1	2.17	0.333
6"	06EE2	2.47	0.667
6"	06EE4	4.93	1.334
8"	08EE1	2.85	0.439
8"	08EE2	3.25	0.878
8"	08EE4	6.5	1.756
10"	10EE1	3.54	0.545
10"	10EE2	4.04	1.091
10"	10EE4	8.07	2.181
12"	12EE1	4.31	0.662
12"	12EE2	4.9	1.325
12"	12EE4	9.8	2.65



EN - Endless Web Slings			
Width	Model	3' base	adder per foot
1"	01EN1	0.34	0.092
1"	01EN2	0.68	0.185
2"	02EN1	0.68	0.183
2"	02EN2	1.36	0.367
3"	03EN1	1.04	0.282
3"	03EN2	2.09	0.564
4"	04EN1	1.38	0.373
4"	04EN2	2.76	0.746
6"	06EN1	2.47	0.667
6"	06EN2	4.93	1.334



RE - Reversed Eye Slings			
Width	Model	3' base	adder per foot
2"	01RE1	0.57	0.169
2"	01RE2	0.91	0.261
4"	02RE1	1.12	0.331
4"	02RE2	1.8	0.515
4"	02RE3	3.16	0.698
4"	02RE4	4.51	0.881
6"	03RE1	1.7	0.502
6"	03RE2	2.75	0.784
6"	03RE3	3.16	0.698
6"	03RE4	6.92	1.347



WEB SLINGS

HH - Hose Handling Slings		
Width	Model	Weight
4"	HH1-94	0.76
6"	HH1-96	1.77
8"	HH1-98	2.57
10"	HH1-910	4.8
12"	HH1-912	6.2
16"	HH2-916	13.66




2B - Two Leg Bridles with master link and eyes only			
Width	Model	3' base	adder per foot
1"	2B01EE1-MEE	2.68	0.092
1"	2B01EE2-MEE	2.76	0.185
2"	2B02EE1-MEE	6.04	0.183
2"	2B02EE2-MEE	6.21	0.367
3"	2B03EE1-MEE	11.4	0.282
3"	2B03EE2-MEE	11.66	0.564



2B - Two Leg Bridles with master link and WS-320 hooks			
Width	Model	3' base	adder per foot
1"	2B01EE1-MHH	4.88	0.092
1"	2B01EE2-MHH	4.96	0.185
2"	2B02EE1-MHH	11.76	0.183
2"	2B02EE2-MHH	11.93	0.367
3"	2B03EE1-MHH	24.6	0.282
3"	2B03EE2-MHH	24.86	0.564




3B - Three Leg Bridles with master link and eyes only




Width	Model	3' base	adder per foot
1"	3B01EE1-MEE	5.75	0.139
1"	3B01EE2-MEE	5.88	0.277
2"	3B02EE1-MEE	11.36	0.275
2"	3B02EE2-MEE	11.61	0.55
3"	3B03EE1-MEE	18.97	0.423
3"	3B03EE2-MEE	19.35	0.845

3B - Three Leg Bridles with master link and WS-320 hooks




Width	Model	3' base	adder per foot
1"	3B01EE1-MHH	9.05	0.139
1"	3B01EE2-MHH	9.18	0.277
2"	3B02EE1-MHH	19.94	0.275
2"	3B02EE2-MHH	20.19	0.55
3"	3B03EE1-MHH	38.77	0.423
3"	3B03EE2-MHH	39.15	0.845

4B - Four Leg Bridles with master link and eyes only



Width	Model	3' base	adder per foot
1"	4B01EE1-MEE	10.77	0.185
1"	4B01EE2-MEE	10.94	0.37
2"	4B02EE1-MEE	18.6	0.367
2"	4B02EE2-MEE	18.93	0.734
3"	4B03EE1-MEE	28.88	0.564
3"	4B03EE2-MEE	29.39	1.127

4B - Four Leg Bridles with master link and WS-320 hooks

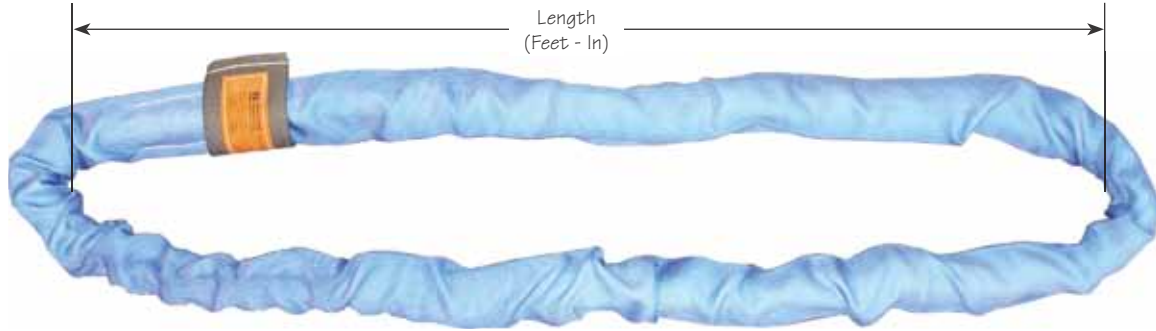


Width	Model	3' base	adder per foot
1"	4B01EE1-MHH	15.17	0.185
1"	4B01EE2-MHH	15.34	0.37
2"	4B02EE1-MHH	30.04	0.367
2"	4B02EE2-MHH	30.37	0.734
3"	4B03EE1-MHH	55.28	0.564
3"	4B03EE2-MHH	55.79	1.127

WEB SLINGS

Roundslings





BLR
Polyester Roundsling

Features:

- Double polyester tubing for better abrasion resistance, and easier inspection
- Orange vinyl tag with clear vinyl cover to protect data
- Vinyl tag sewn on a buffer web sleeve that allows the tag to float freely around the sling
- Design factor of 5 to 1

How to order:

- Combine model, length in feet, and type

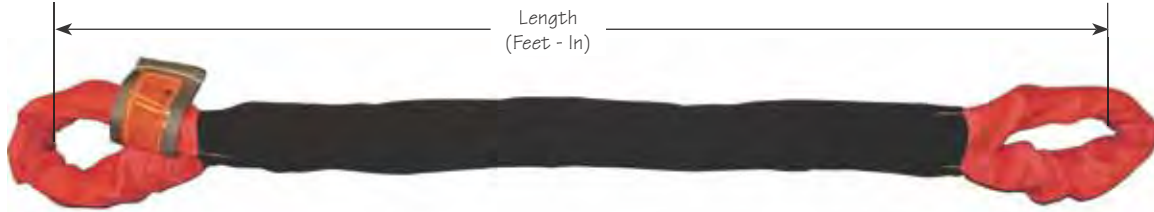
⚠ WARNING

See roundsling warnings page for warnings and inspection criteria

Part. Number		Color	Approx Dia. Inch	Wt. per Ft. per foot.	Capacities in Lbs.		
Model	Length				Vertical Hitch	Choke Hitch	Vertical Basket Hitch
BLR1	*	Purple	.60	.30	2,600	2,100	5,200
BLR2	*	Green	.80	.40	5,300	4,200	10,600
BLR3	*	Yellow	1.00	.50	8,400	6,700	16,800
BLR4	*	Tan	1.20	.65	10,600	8,500	21,200
BLR5	*	Red	1.30	.80	13,200	10,600	26,400
BLR6	*	White	1.45	1.00	16,800	13,400	33,600
BLR7	*	Blue	1.55	1.20	21,200	17,000	42,400
BLR8	*	Orange	1.75	1.50	25,000	20,000	50,000
BLR9	*	Gray	1.95	2.00	31,000	24,800	62,000
BLR10	*	Orange	2.35	2.80	40,000	32,000	80,000
BLR11	*	Brown	3.15	3.60	53,000	42,400	106,000
BLR12	*	Olive	3.95	4.60	66,000	52,800	132,000
BLR13	*	Black	4.50	5.60	90,000	72,000	180,000
BLR14	*	Black	5.0	6.00	103,200	82,650	206,400

Note:

- See weights page for weights



BLR-EE

Polyester Roundsling, eye and eye type

Features:

- 2 layers of buffer tubing increase durability
- Orange vinyl tag with clear vinyl cover to protect data
- Vinyl tag sewn on a buffer web sleeve
- Design factor of 5 to 1

How to order:

- Combine model, length in feet, and type

WARNING
See roundsling warnings page
for warnings and inspection criteria

Part. Number			Color	Approx Dia. Inch	Wt. per Ft. per foot.	Capacities in Lbs.		
Model	Length	Type				Vertical Hitch	Choke Hitch	Vertical Basket Hitch
BLR1	*	-EE	Purple	.60	.30	2,600	2,100	5,200
BLR2	*	-EE	Green	.80	.40	5,300	4,200	10,600
BLR3	*	-EE	Yellow	1.00	.50	8,400	6,700	16,800
BLR4	*	-EE	Tan	1.20	.65	10,600	8,500	21,200
BLR5	*	-EE	Red	1.30	.80	13,200	10,600	26,400
BLR6	*	-EE	White	1.45	1.00	16,800	13,400	33,600
BLR7	*	-EE	Blue	1.55	1.20	21,200	17,000	42,400
BLR8	*	-EE	Orange	1.75	1.50	25,000	20,000	50,000
BLR9	*	-EE	Gray	1.95	2.00	31,000	24,800	62,000
BLR10	*	-EE	Orange	2.35	2.80	40,000	32,000	80,000
BLR11	*	-EE	Brown	3.15	3.60	53,000	42,400	106,000
BLR12	*	-EE	Olive	3.95	4.60	66,000	52,800	132,000
BLR13	*	-EE	Black	4.50	5.60	90,000	72,000	180,000
BLR14	*	-EE	Black	5.0	6.00	103,200	82,650	206,400

Note:

- See weights page for weights

SWC1

Sliding Sleeve, 1 ply heavy duty nylon webbing both sides, sewn both sides with ends open

SWC2

Sliding Sleeve, 2 ply heavy duty nylon webbing both sides, sewn both sides with ends open



Features:

- Protects the sling from localized abrasion
- Heavy duty nylon webbing
- Sewn both sides
- Can slide on the sling and be positioned in a specific location

How to order:

- Combine model and length

Part Number – 1 ply		Width	Sling Width
Model	Length		
03SWC1	*	3"	1"
04SWC1	*	4"	2"
06SWC1	*	6"	3"
08SWC1	*	8"	4"
10SWC1	*	10"	6"
12SWC1	*	12"	8"
16SWC1	*	16"	10-12"
Part Number – 2 ply			
03SWC2	*	3"	1"
04SWC2	*	4"	2"
06SWC2	*	6"	3"
08SWC2	*	8"	4"
10SWC2	*	10"	6"
12SWC2	*	12"	8"
16SWC2	*	16"	10-12"

SBV2

Sliding Sleeve, 2 ply, heavy duty web inner plies, buffer webbing outer plies, sewn closed one side with Velcro closure other side



Features:

- Protects the sling from localized abrasion
- Heavy duty nylon and buffer webbing
- Easily attached and removed with the Velcro closure
- Can slide on the sling and be positioned in a specific location

How to order:

- Combine model and length

Part Number		Width	Sling Width
Model	Length		
03SBV2	*	3"	1"
04SBV2	*	4"	2"
06SBV2	*	6"	3"
08SBV2	*	8"	4"
10SBV2	*	10"	6"
12SBV2	*	12"	8"
16SBV2	*	16"	10-12"

Model: SFV1

Sliding Sleeve, 1 ply, white felt sewn closed one side with Velcro closure other side

Features:

- Protects the sling from localized abrasion
- Heavy duty 3/8" thick white felt
- Easily attached and removed with the Velcro closure
- Can slide on the sling and be positioned in a specific location
- Larger widths available upon request

How to order:

- Combine model and length



Part Number		Width	Sling Width
Model	Length		
03SFV1	*	3"	1"
04SFV1	*	4"	2"
06SFV1	*	6"	3"
08SFV1	*	8"	4"
10SFV1	*	10"	6"
12SFV1	*	12"	8"
16SFV1	*	16"	10-12"

Model: SFV2

Sliding Sleeve, 2 ply, nylon web inner lined with white felt outer layers, sewn closed one side with Velcro closure other side

Features:

- Protects the sling from localized abrasion
- Heavy duty nylon webbing and 3/8" thick white felt
- Easily attached and removed with the Velcro closure
- Can slide on the sling and be positioned in a specific location
- Larger widths available upon request

How to order:

- Combine model and length



Part Number		Width	Sling Width
Model	Length		
03SFV2	*	3"	1"
04SFV2	*	4"	2"
06SFV2	*	6"	3"
08SFV2	*	8"	4"
10SFV2	*	10"	6"
12SFV2	*	12"	8"
16SFV2	*	16"	10-12"

Synthetic Armor Pads protect the slings from abrasion damage which can be caused by contact with rough surfaces such as concrete beams and structures. They are also used to protect finished or painted loads from marring. These wear pads can be made to fit any length or width sling. They can also be made in long lengths which the customer can cut into suitable sizes on the job. Double or triple thickness provides resistance for the more severe conditions. There is no maximum width and a variety of materials are used to protect slings and to protect loads.

SYNARM-SL – Synthetic Armor Pads

Sliding type, 2 ply heavy duty tubing both sides, filled with white felt, with ends open

Features:

- Protects the sling from localized abrasion
- Extra Heavy duty Covermax® tubing
- 3/8" high density white felt filled both sides
- Can slide on the sling and be positioned in a specific location

How to order:

- Combine model and length



Part Number		Width	Sling Width
Model	Length		
03SYNARM-SL	*	3"	1"
04SYNARM-SL	*	4"	2"
06SYNARM-SL	*	6"	3"
08SYNARM-SL	*	8"	4"
10SYNARM-SL	*	10"	6"
12SYNARM-SL	*	12"	8"

SYNARM-RM – Synthetic Armor Pad

Removable type, 2 ply tubing both sides, filled with white felt, with Velcro closure one side

Features:

- Protects the sling from localized abrasion
- Extra Heavy duty Covermax® tubing
- 3/8" high density white felt filled both sides
- Easily attached and removed with the Velcro closure
- Can slide on the sling and be positioned in a specific location
- Larger widths available upon request

How to order:

- Combine model and length



Part Number		Width	Sling Width
Model	Length		
03SYNARM-RM	*	3"	1"
04SYNARM-RM	*	4"	2"
06SYNARM-RM	*	6"	3"
08SYNARM-RM	*	8"	4"
10SYNARM-RM	*	10"	6"
12SYNARM-RM	*	12"	8"

SYNARM-EE – Synthetic Armor Pad

Eye and eye type, 2 ply tubing both sides, filled with white felt, with installation and removal handles each end

Features:

- Fits over both legs of an endless sling to enable it to be used like an eye and eye sling
- Protects the sling from localized abrasion
- Extra Heavy duty Covermax® tubing
- 3/8" high density white felt filled both sides
- Handle sewn each end
- Larger widths available upon request

How to order:

- Combine model and length



Part Number		Width	Sling Width
Model	Length		
03SYNARM-EE	*	3"	1"
04SYNARM-EE	*	4"	2"
06SYNARM-EE	*	6"	3"
08SYNARM-EE	*	8"	4"
10SYNARM-EE	*	10"	6"
12SYNARM-EE	*	12"	8"



CRNMX – CornerMax™ Pad

Edge protection, 1 ply web filled with 3/4" nylon rods, with 2 Velcro closures

Features:

- CornerMax™ Pad forms a tunnel between the load edge and the pad
- Position on corners or edges of the load
- Pad protects sling because of zero contact
- Filled with 3/4" nylon round bars
- Easily attached and removed with the Velcro closure
- Custom widths and sizes available upon request

How to order:











- Specify part number

Part Number	Width	Sling Width
CRNMX02	4"	Up to 2"
CRNMX03	5"	3"
CRNMX04	6"	4"
CRNMX05	8"	5"
CRNMX06	8"	6"
CRNMX08	10"	8"
CRNMX10	12"	10"



! ROUNDSLING WARNINGS

When inspecting a roundsling, it shall be taken out of service immediately and returned for repair or replacement when any of the below defects are present

Missing or illegible sling identification (tag)		Weld splatter that exposes core yarns	
Acid or caustic burns		Knots in any part of the sling	
Evidence of heat damage		Fittings that are pitted, corroded, cracked, bent, twisted, gouged, or broken	
Holes, tears, cuts, abrasive wear, or snags that expose core yarns		Damaged hooks per ASME B30.10	
Broken or damaged core yarns		Damaged rigging hardware per ASME B30.26	

and... Any condition that causes doubt about the continued use of the sling

Roundslings Identification, Inspection, Rigging Practices

Synthetic Web Slings are designed and built to be easy to use and versatile. As with any quality product certain precautions and standards of treatment should be observed. Proper care will extend the useful life of roundslings.

Follow the Guidelines set forth in ASME B30.9 “Slings” standard, OSHA 1910.184 and 1926.251.

Sling Identification

Each sling shall be marked to show the following:

- Name or Trademark of manufacturer
- Manufacturer’s code or stock number
- Rated loads for the type(s) of hitch(es) used and the angle upon which it is based
- Core material
- Cover material, if different from core material
- Number of legs, if more than one

Sling identification shall be done by the sling manufacturer, and should be maintained by the user so as to be legible during the life of the sling.

Inspection

Synthetic Web Sling inspection falls into 3 categories. Initial, Frequent, and Periodic.

- **Initial Inspection**– Prior to use, all new, altered, modified, or repaired slings shall be inspected by a designated person to verify compliance with the applicable provisions of this chapter
- **Frequent Inspection**
 - o A visual inspection for damage shall be performed by the user or other designated person each day or shift the sling is used
 - o Conditions such as those listed in the removal criteria section or any other condition that may result in a hazard shall not be returned to service until approved by a qualified person
 - o Written records are not required for frequent inspections
- **Periodic Inspections**
 - o A complete inspection for damage to the sling shall be periodically performed by a designated person. Each sling and component shall be examined individually, taking care to expose and examine all surfaces. The sling shall be examined for conditions such as those listed in the removal criteria section and a determination made as to whether they constitute a hazard
 - o Periodic Inspection Frequency – Periodic inspection intervals shall not exceed 1 year. The frequency of periodic inspections should be based on:
 - Frequency of sling use
 - Severity of service condition
 - Nature of lifts being made
 - Experience gained on the service life of slings used in similar circumstances
 - o Guidelines for time intervals are:
 - Normal service – yearly
 - Severe service – monthly to quarterly
 - Special service – as recommended by a qualified person
 - o A written record of the most recent periodic inspection shall be maintained

Removal Criteria

A roundslings shall be removed from service if the following conditions are present.

- Missing or illegible sling identification (tag or markings)
- Acid or caustic burns
- Evidence of heat damage
- Holes, tears, cuts, or snags that expose the core yarns
- Broken or damaged core yarns
- Weld splatter that exposed core yarns
- Roundslings that are knotted
- Fittings that are pitted, corroded, cracked, bent, twisted, gouged, or broken
- Damaged hooks, removal criteria as stated in ASME B30.10
- Damaged rigging hardware, removal criteria as stated in ASME B30.26
- Other conditions, including visible damage, that cause doubt as to the continued use of the sling

Rigging Practices

- Slings shall be shortened or adjusted only by methods approved by the sling manufacturer or a qualified person
- Slings shall be hitched in a manner providing control of the load
- Slings in contact with edges, corners, or protrusions should be protected with a material of sufficient strength, thickness, and construction to prevent damage to the sling
- Shock loading should be avoided

- Loads should not be rested on the sling
- Slings should not be pulled from under the load when the load is resting in the sling
- Twisting shall be avoided
- During lifting, with or without load, personnel shall be alert for possible snagging
- When using multiple basket or choker hitches, the load should be rigged to prevent the sling from slipping or sliding along the load
- When using a basket hitch, the legs of the sling should contain or support the load from the sides, above the center of gravity, so that the load remains under control
- Slings should not be dragged on the floor or over an abrasive surface
- In a choker hitch, the choke point should only be on the sling body, not on a splice or fitting
- In a choker hitch, an angle of choke less than 120 degrees should not be used without reducing the rated load
- Slings should not be constricted, bunched, or pinched by the load, hook, or any fitting
- The load applied to the hook should be centered in the base (bowl) of the hook to prevent point loading on the hook, unless the hook is designed for point loading
- Slings shall not be shortened or lengthened by knotting or twisting

Environmental Considerations

Temperature

- Polyester and nylon webbing slings shall not be used in contact with an object or at temperatures in excess of 194°F (90°C) or below (-40°C)
- Some synthetic yarns do not retain their published breaking strength above 140°F (60°C). The roundsling manufacturer should be consulted for the temperature range of roundslings made from other synthetic materials

Chemically Active Environments

- The strength of synthetic web slings can be degraded by chemically active environments. This includes exposure to chemicals in the form of solids, liquids, gases, vapors, or fumes. The sling manufacturer or qualified person should be consulted before slings are used in chemically active environments

Sources:

ASME B30.9 “Slings” Standard


WSTDA “Web Sling and Tie-Down Association

OSHA 1910.184 “Slings”

OSHA 1926.251 “Rigging Equipment for material handling”

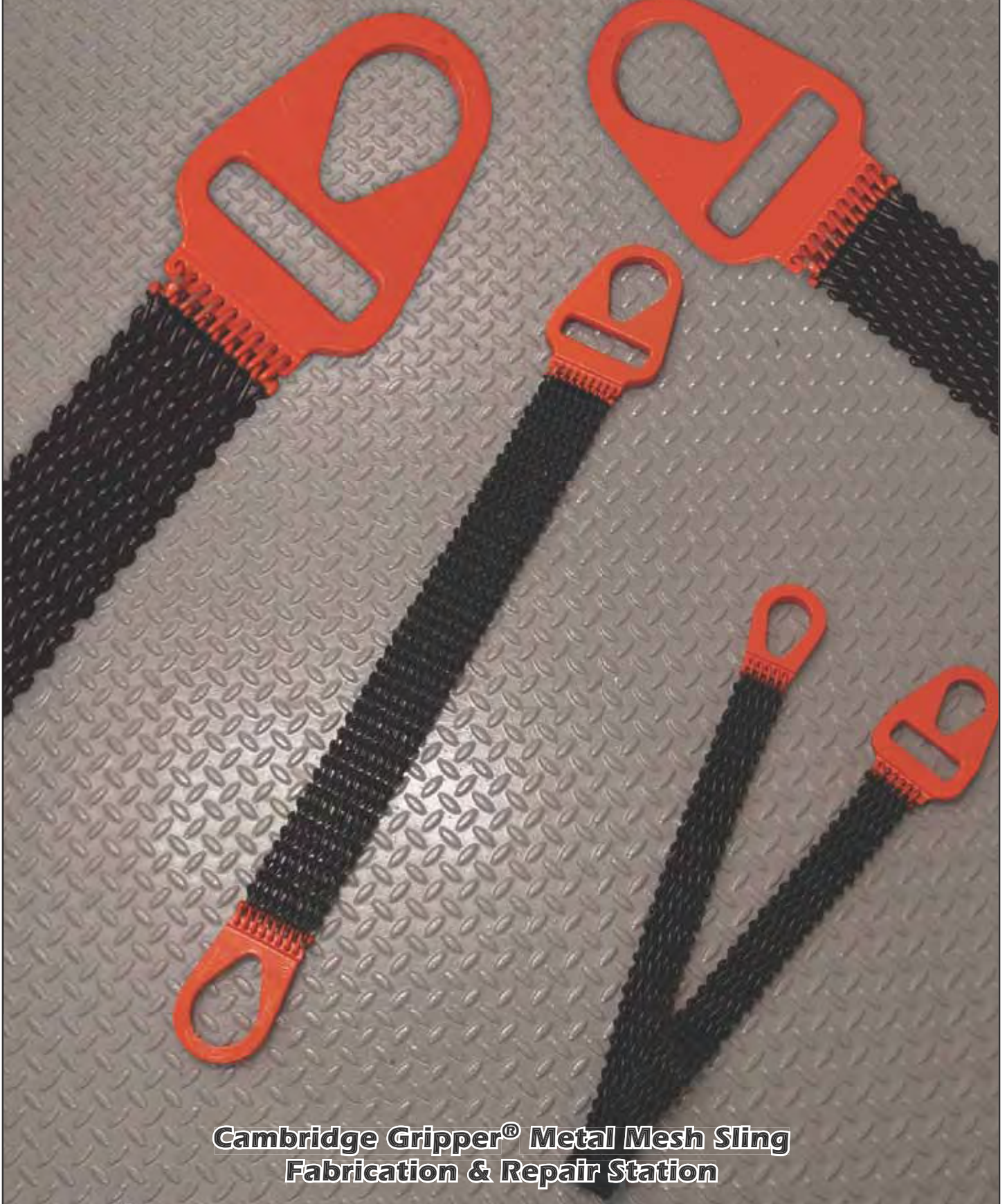
Weight Tables

BLR - Roundsling		
Model	Body Color	Adder per foot
BLR1	Purple	0.6
BLR2	Green	0.8
BLR3	Yellow	1
BLR4	Tan	1.2
BLR5	Red	1.3
BLR6	White	1.5
BLR7	Blue	1.55
BLR8	Orange	1.75
BLR9	Grey	1.95
BLR10	Orange	2.35
BLR11	Brown	3.15
BLR12	Olive	3.95
BLR13	Black	4.5
BLR14	Black	5.0

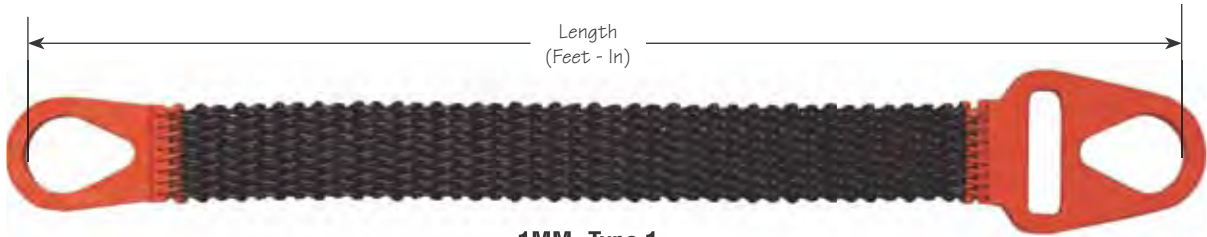
BLR-EE - Roundsling, Eye and Eye		
Model	Eye Color	Adder per foot
BLR1-EE	Purple	0.63
BLR2-EE	Green	0.84
BLR3-EE	Yellow	1.05
BLR4-EE	Tan	1.26
BLR5-EE	Red	1.37
BLR6-EE	White	1.58
BLR7-EE	Blue	1.63
BLR8-EE	Orange	1.84
BLR9-EE	Grey	2.05
BLR10-EE	Orange	2.47
BLR11-EE	Brown	3.31
BLR12-EE	Olive	4.15
BLR13-EE	Black	4.73
BLR14-EE	Black	5.00

Metal Mesh Slings

Gripper® Wire Mesh Slings



**Cambridge Gripper® Metal Mesh Sling
Fabrication & Repair Station**



1MM -Type 1

Metal mesh sling with choker and basket fitting

Features:

- G-35 heavy duty metal mesh, carbon steel, 10 gauge
- Tolerates temperatures up to 550° F, or even higher, when made of special alloy
- Available in T-304 stainless steel, T-316 stainless steel, monel, and 4130 alloy upon request
- Proof tested to 2X rated capacity
- Design factor of 5 to 1

How to order:

- Combine model and length in feet

⚠ WARNING

See metal mesh slings warnings page for warnings and inspection criteria

Part Number		Width Inches	Rated Capacities in Lbs.				
Model Type 1	Length Feet		Choker	Vertical Basket	Basket 60° from Horizontal	Basket 45° from Horizontal	Basket 30° from Horizontal
1MM02X	*	2	1,600	3,200	2,700	2,000	1,600
1MM03X	*	3	3,000	6,000	5,100	3,800	2,800
1MM04X	*	4	4,400	8,800	7,480	5,600	4,400
1MM06X	*	6	6,600	13,200	11,225	8,400	6,600
1MM08X	*	8	8,800	17,600	15,000	11,250	8,800
1MM10X	*	10	11,000	22,000	18,700	14,000	11,000
1MM12X	*	12	13,200	26,400	22,440	16,800	13,200
1MM14X	*	14	15,400	30,800	26,180	19,600	15,400
1MM16X	*	16	17,600	35,200	29,920	22,400	17,600
1MM18X	*	18	19,800	39,600	33,660	25,200	19,800
1MM20X	*	20	22,000	44,000	37,400	28,000	22,000

Note:

- See dimensional data page for weights



2MM -Type 2

Metal mesh sling with basket fitting each end

Features:

- G-35 heavy duty metal mesh, carbon steel, 10 gauge
- Tolerates temperatures up to 550° F, or even higher, when made of special alloy
- Available in T-304 stainless steel, T-316 stainless steel, monel, and 4130 alloy upon request
- Proof tested to 2X rated capacity
- Design factor of 5 to 1

How to order:

- Combine model and length in feet

⚠ WARNING

See metal mesh slings warnings page
for warnings and inspection criteria

Part Number		Width Inches	Rated Capacities in Lbs.			
Model Type 2	Length Feet		Vertical Basket	Basket 60° from Horizontal	Basket 45° from Horizontal	Basket 30° from Horizontal
2MM02X	*	2	3,200	2,700	2,000	1,600
2MM03X	*	3	6,000	5,100	3,800	2,800
2MM04X	*	4	8,800	7,480	5,600	4,400
2MM06X	*	6	13,200	11,225	8,400	6,600
2MM08X	*	8	17,600	15,000	11,250	8,800
2MM10X	*	10	22,000	18,700	14,000	11,000
2MM12X	*	12	26,400	22,440	16,800	13,200
2MM14X	*	14	30,800	26,180	19,600	15,400
2MM16X	*	16	35,200	29,920	22,400	17,600
2MM18X	*	18	39,600	33,660	25,200	19,800
2MM20X	*	20	44,000	37,400	28,000	22,000

Note:

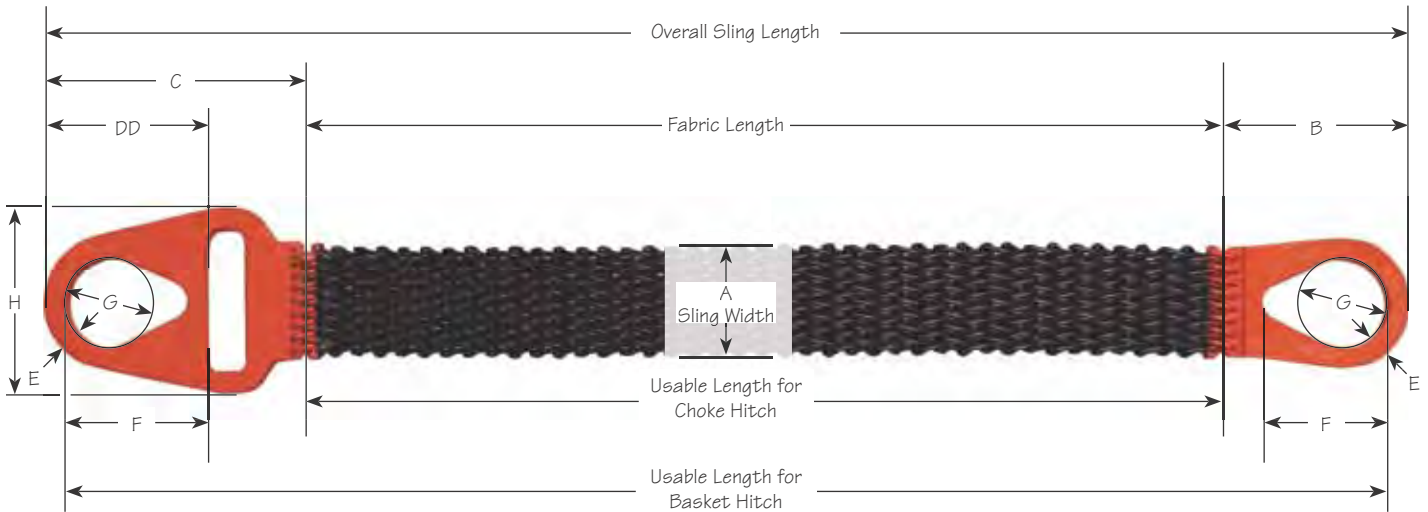
- See dimensional data page for weights

⚠ METAL MESH SLING WARNINGS

When inspecting a metal mesh sling, it shall be taken out of service immediately and returned for repair or replacement when any of the below defects are present.

Missing or illegible sling identification		Distortion of either fitting so that the width of the eye opening is decreased more than 10%	
Broken weld or a broken brazed joint along the sling edge		A 15% reduction of the original cross-sectional area of any point around the hook opening of the end fitting	
Broken wire in any part of the mesh		Visible distortion of either end fitting out of its plane	
Reduction in wire diameter of 25% due to abrasion, or 15% due to corrosion		Cracked end fitting	
Lack of flexibility in the mesh due to distortion of the mesh		Slings in which the spirals are locked or without free articulation shall not be used	
Distortion of the choker fitting so the depth of the slot is increased by more than 10%		Fittings that are pitted, corroded, cracked, bent, or twisted, gouged, or broken	

and... Any condition that causes doubt about the continued use of the sling



Dimensional Data

Sling Width	See drawing above								Hook Size	Approx. Wt. per 36" sling length	10 ga. fabric lbs. per foot
	A"	B"	C"	D"	E"	F"	G"	H"			
2	4	6	2	.5	2.75	1.75	4	3.75	5T	5	1.25
3	5.25	7.5	3	.75	3.5	2.5	5.25	5	10T	8	1.87
4	5.5	7.75	4	.75	3.5	2.5	6.25	5	10T	10	2.5
6	6.5	9	6	1	4	2.75	8.5	6	15T	15	3.87
8	8.75	12	8	1.25	5.5	4	11.25	8.5	25T	20	5.12
10	9.375	12.93	9.93	1.37	5.5	4	13.5	9.87	25T	33	6.37
12	10.25	13.93	12	1.5	6	4.5	15.75	10.5	30T	42	7.62
14	10.62	14.69	13.87	1.62	6	4.5	18	10.62	30T	47	8.87
16	11.25	15.56	15.87	1.75	6	4.5	20.25	10.75	30T	55	10.25
18	11.87	16.56	17.87	1.87	6	4.5	22.5	10.87	30T	64	11.37
20	12.5	17.56	19.87	2	6	4.5	24.75	11	30T	73	12.75

Chemical Environment Data

Metal Mesh	Weak Sulphuric Acid	Weak Hydrochloric Acid	Alkaline Caustic Solutions	Salt Solutions	Organic Solvents	Water
Carbon Steel	No	No	No	No	Yes	No
T-304 Stainless Steel	No	No	Yes	No	Yes	Yes
T-316 Stainless Steel	No	No	Yes	No	Yes	Yes
Monel	No	No	Yes	Yes	Yes	Yes
AISI 4130 Alloy Steel	No	No	No	No	Yes	No

Metal Mesh Slings Identification, Inspection, and Rigging Practices

Metal Mesh Slings are designed and built for rugged lasting service. As with any quality product certain precautions and standards of treatment should be observed. Proper care will extend the useful life of the metal mesh sling.

Follow the Guidelines set forth in ASME B30.9 “Slings” standard, OSHA 1910.184 and 1926.251.

Sling Identification

- Each Metal mesh sling shall be marked to show the following
- Name or Trademark of manufacturer
- Rated loads for the type(s) of hitch(es) used and the angle upon which it is based
- Width and gauge
- Number of legs, if more than one
- Individual sling identification (e.g., serial numbers)

Sling identification shall be done by the sling manufacturer, and should be maintained by the user so as to be legible during the life of the sling.

Inspection

Metal Mesh Sling inspection falls into 3 categories. Initial, Frequent, and Periodic.

- **Initial Inspection**— Prior to use, all new, altered, modified, or repaired slings shall be inspected by a designated person to verify compliance with the applicable provisions of this chapter
- **Frequent Inspection**
 - o A visual inspection for damage shall be performed by the user or other designated person each day or shift the sling is used
 - o Conditions such as those listed in the removal criteria section or any other condition that may result in a hazard shall not be returned to service until approved by a qualified person
 - o Written records are not required for frequent inspections
- **Periodic Inspections**
 - o A complete inspection for damage to the sling shall be periodically performed by a designated person. Inspection shall be conducted on the entire length including splices, end attachments, and fittings. The sling shall be examined for conditions such as those listed in the removal criteria section and a determination made as to whether they constitute a hazard
 - o Periodic Inspection Frequency – Periodic inspection intervals shall not exceed 1 year. The frequency of periodic inspections should be based on:
 - Frequency of sling use
 - Severity of service condition
 - Nature of lifts being made
 - Experience gained on the service life of slings used in similar circumstances
 - o Guidelines for time intervals
 - Normal service – yearly
 - Severe service – monthly to quarterly
 - Special service – as recommended by a qualified person
 - o A written record of the most recent periodic inspection shall be maintained

Removal Criteria

A wire rope sling shall be removed from service if the following conditions are present.

- o Missing or illegible sling identification (tag or markings)
- o Broken weld or broken brazed joint along the sling edge
- o Broken wire in any part of the mesh
- o Reduction in the wire diameter of 25% due to abrasion or 15% due to corrosion
- o Lack of flexibility due to distortion of the mesh
- o Distortion of the choker fitting so the depth of the slot is increased by more than 10%
- o Distortion of either end fitting so the width of the eye opening is decreased by more than 10%
- o A 15% reduction of the original cross-sectional area of any point around the hook opening of the end fitting
- o Visible distortion of either end fitting out of its plane
- o Cracked end fitting
- o Slings in which the spirals are locked or without free articulation shall not be used
- o Fittings that are pitted, corroded, cracked, bent, twisted, gouged or broken
- o Other conditions, including visible damage that can cause doubt as to the continued use of the sling

Rigging Practices

- Slings shall be shortened or adjusted only by methods approved by the sling manufacturer or a qualified person
- The load shall be evenly distributed across the width of the metal mesh
- The sling shall be hitched in a manner providing control of load
- Slings in contact with edges, corners, or protrusions should be protected with a material of sufficient strength, thickness, and construction to prevent damage

- Shock loading should be avoided
- Loads should not be rested on the sling
- Slings should not be pulled from under a load while the load is resting on the sling
- Twisting and kinking shall be avoided
- During lifting, with or without load, personnel shall be alert for possible snagging
- In a basket hitch, the load should be balanced to prevent slippage
- When using a basket hitch, the sling should contain or support the load from the sides, above the center of gravity, so that the load remains under control
- Slings should not be dragged on the floor or over an abrasive surface
- In a choker hitch, and angle of choke less than 120° should not be used without reducing the rated load
- Slings should not be constricted, bunched, or pinched by the load, hook, or any fitting
- In a choker hitch, the load should be balanced to prevent edge overload
- Straightening a spiral or cross rod or forcing a spiral into position shall not be done
- Slings used in pairs should be attached to a spreader beam

Environmental Considerations

Temperature

- Metal mesh slings shall not be subjected to a reduction in rated capacity if used in temperatures below -20°F (-29°C) and above 550°F (288°)
- Metal mesh slings coated in elastomer should be used only in a temperature range of 0°F (-18°C) to 200°F (93°C)

Chemically Active Environments

- The strength of metal mesh slings can be degraded by chemically active environments. This includes exposure to chemicals in the form of solids, liquids, gases, vapors, or fumes. The sling manufacturer or qualified person should be consulted before slings are used in chemically active environments

Sources:

ASME B30.9 “Slings” Standard

OSHA 1910.184 “Slings”

OSHA 1926.251 “Rigging Equipment for material handling”

Definitions of Terms

Abrasion: The mechanical wearing of surface resulting from frictional contact with materials or objects.

Breaking Strength: That total force (lbs. or kg.) at which the sling fails. The total weight strain which can be applied before failure. Usually at five times the rated capacity.


Competent Person: A person designated for inspection who is trained, qualified by knowledge and practical experience and the necessary instructions to enable the required test or examination to be carried out.

Twin-Path® Core: The load bearing multiple fibers of polyester, aramids, or K-Spec® which when wound into the seamless tubes become the load bearing yarns of the sling. If other materials are used follow the manufacturers recommendations.


Twin-Path® Cover: The seamless tubes, usually at least two separate and contrasting colors for easier inspection that contain the cores. Covers may be of polyester, Covermax® nylon, or aramids depending on the desired finished characteristics of the product.

Elongation: The measurement of stretch, expressed as a percentage of the finished length.

Fitting: A load bearing metal component which is fitted to the sling. Can be of steel, aluminum, or other material that will sustain the rated capacity of the sling.

Hitch/Vertical:  A method of attachment whereby the sling extends from the crane hook to the load in a straight connection.

Hitch/Choker:  The sling is passed around the load and back through itself and is connected to the crane hook. The sling then tightens around the load when it is strained.

Hitch/Basket:  The sling is passed from the crane hook around the load and attached to the crane hook.

Length: The distance between bearing points of the sling.

Proof Load Test: A non-destructive load test usually to twice the rated capacity of the sling.

Proof Test: The “proof test” is a quality control test applied to chain for the purpose of verifying weld and material quality. It is the minimum force in pounds or newtons that the chain has withstood in direct tension as a part of the manufacturing process. Proof Testing assures that the chain is more than capable of performing at its rated working load limit. Proof test loads are a manufacturing integrity test and shall not be used as criteria for service or design purposes.

Rated Capacity: Rated Capacity (RC) – The “rated capacity” is the maximum combined static and dynamic load in pounds or Kilograms which should ever be applied to the product in service, even when the product is new, and when the load is uniformly applied in direct tension to the product.

Synthetic Fiber: Man-made material used for the cover, the core and the thread of the Twin-Path® sling products.

Tell-Tails: Tell-Tails which extend past the tag area of each sling. Extension of the load core yarns. When the sling is stretched beyond its elastic limit, they shrink and eventually disappear under the tag. Take out of service if tell-tails are not visible.

Thread: The synthetic yarn which is used to sew the sling covers and tag and to provide the stitch which separates the individual load cores.

Twin-Path® Sling: A patented and trademarked product which is composed of two separate load cores and two contrasting color covers.

Basic Lift Engineering

Every Lift Uses 1 of 3 Basic Hitches

STRAIGHT OR VERTICAL, attachment, is simply using a sling to connect a lifting hook to a load. Full rated lifting capacity of the sling may be utilized, but must not be exceeded. Whenever a single sling is used in this manner, a tagline should be used to prevent load rotation which may cause damage to the sling.

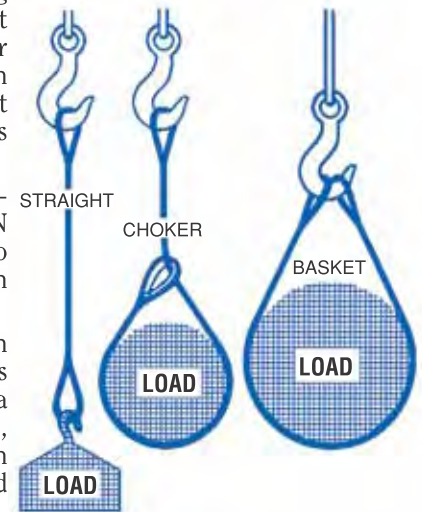
When two or more slings are attached to the same lifting hook in straight or vertical, manner, the total hitch becomes, in effect, a lifting bridle, and the load is distributed among the individual slings.

CHOKER hitches reduce lifting capability of a sling, since this method of rigging affects ability of the wire rope components to adjust during the lift. A choker is used when the load will not be seriously damaged by the sling body—or the sling damaged by the load, and when the lift requires the sling to snug up against the load.

The diameter of the bend where the sling contacts the load should keep the point of choke against the sling **BODY** — never against a splice or the base of the eye. When a choke is used, the sling rated capacity must be adjusted downward to compensate for loss of capability.

A choker hitch should be pulled tight before a lift is made — **NOT PULLED DOWN DURING THE LIFT**. It is also dangerous to use only one choker hitch to lift a load which might shift or slide out of the choke.

BASKET hitches distribute a load between the two legs of a sling — within limitations described below. Capacity of a sling used in a basket is affected by the bend or curvature, where the sling body comes in contact with the load— just as any sling is affected and limited by bending action, as over a sheave.



Calculating the Load on Each Leg of a Sling

As the horizontal angle between the legs of a sling decreases, the load on each leg increases. The effect is the same whether a single sling is used as a basket or two slings are used with each in a straight pull, as with a 2-legged bridle.

Anytime pull is exerted at an angle on a leg—or legs—of a sling, the load per leg can be determined by using the data in the table at right. Proceed as follows to calculate this load—and determine the rated capacity required of the sling or slings, needed for a lift.

1. First, divide the total load to be lifted by the number of legs to be used. This provides the load per leg if the lift were being made with all legs lifting vertically.
2. Determine the angle.

3. Then **MULTIPLY** the load per leg (as computed in No. 1 above) by the Load Factor for the leg angle being used (from the table at right) — to compute the **ACTUAL LOAD** on each leg for this lift and angle. **THE ACTUAL LOAD MUST NOT EXCEED THE RATED SLING CAPACITY.**

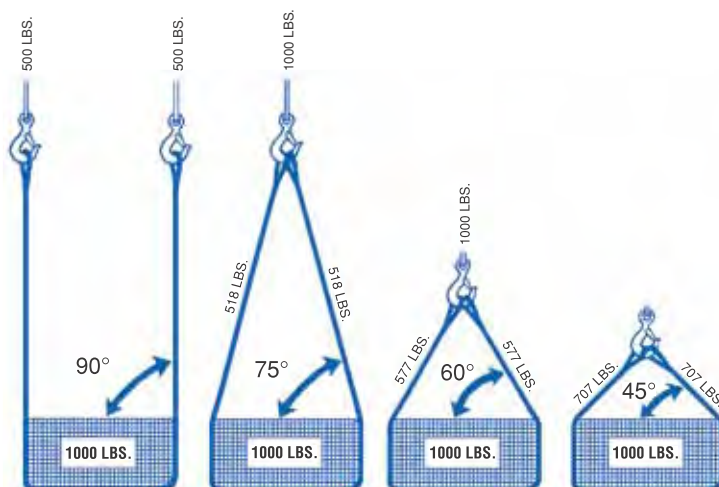
Thus, in drawing three (sling angle at 60°): $1000 / 2 = 500$ (Load Per Leg if a vertical lift)

$500 \times 1.154 = 577$ lbs. = **ACTUAL LOAD** on each leg at the 60° **HORIZ** angle being used.

In drawing four (sling angle of 45°):

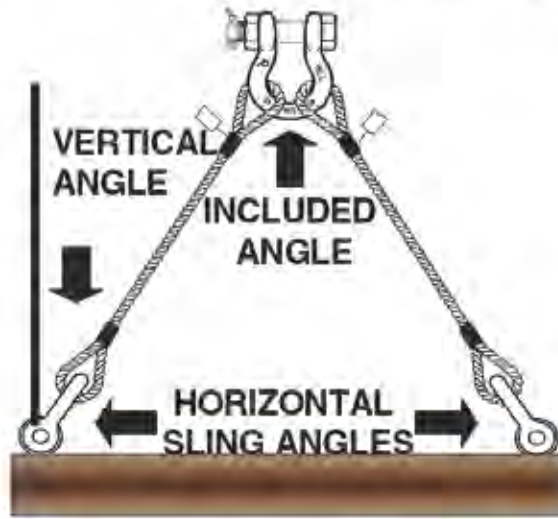
$1000 / 2 = 500$ (Load Per Leg if a vertical lift)

$500 \times 1.414 = 707$ lbs. = **ACTUAL LOAD** on each leg at the 45° **HORIZ** angle being used.



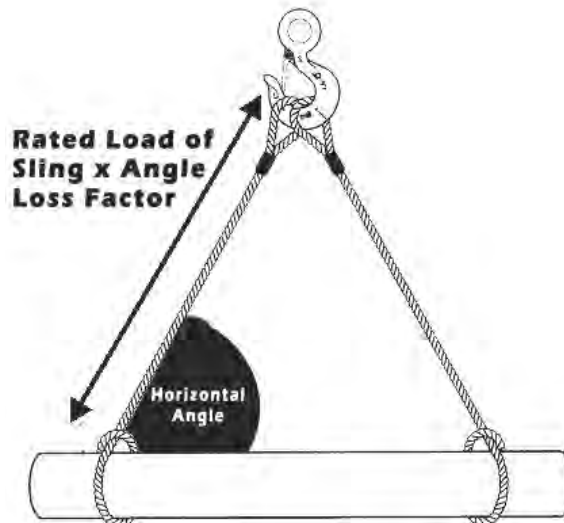
LEG ANGLE (Degrees)	LOAD FACTOR
90°	1.000
85°	1.003
80°	1.015
75°	1.035
70°	1.064
65°	1.103
60°	1.154
55°	1.220
50°	1.305
45°	1.414

THE RIGGING TRIANGLE



Rated capacities are affected by angle of lift (sling to load) measured from the horizontal when used with multi-legged slings or choker/basket hitches. To determine the actual sling capacity at a given angle of lift, multiply the original sling rating by the appropriate loss factor determined from the table below.

Sling Angle Table – Reducing Load				
Angle/ Degrees from Horizontal	Loss Factor		Angle/ Degrees from Horizontal	Loss Factor
90	1.000		55	0.819
85	0.996		50	0.766
80	0.985		45	0.707
75	0.966		40	0.643
70	0.940		35	0.574
65	0.906		30	0.500
60	0.866		Do not use below 30°	



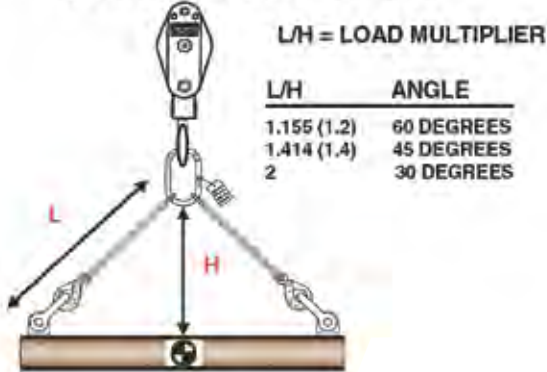
When you know the angle:

- Load x Load angle factor = sling tension

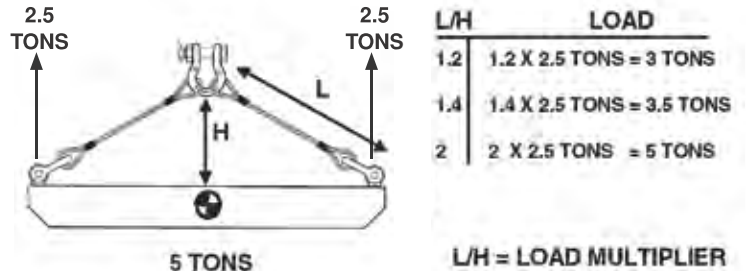
When you know the sling length and height:

- L/H x Load = sling tension per legs

MEASURE THE HORIZONTAL SLING ANGLE BY USE OF L/H



CALCULATE THE LOAD IN EACH SLING LEG BY USE OF L/H

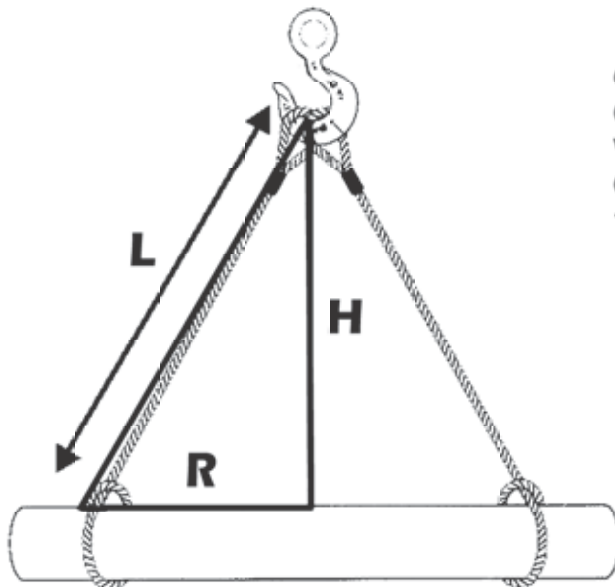


Load Factor Table – Increasing Loads			
Horizontal Angle	Load Angle Factor	Horizontal Angle	Load Angle Factor
90	1.000	55	1.221
85	1.004	50	1.305
80	1.015	45	1.414
75	1.035	40	1.555
70	1.064	35	1.742
65	1.104	30	2.00
60	1.155	Slings below 30° should not be used	

Finding Sling Length (L), Height (H), or Run (R)		
Find L (sling length)	Find R (run)	Find H (height)
$H^2 + R^2 = L^2$	$L^2 - H^2 = R^2$	$L^2 - R^2 = H^2$

WIRE ROPE SLINGS

**CHOKER HITCH
CAPACITY REDUCTION
WHEN ANGLE OF
CHOKE LESS THAN
120 DEGREES**



ANGLE OF CHOKE	CAPACITY % OF CHOKER (ASME B30.9)	CAPACITY % OF VERTICAL (ESTIMATED)
120° - 180°	100%	75%
90° - 120°	87%	65%
60° - 89°	74%	55%
30° - 59°	62%	46%
0° - 29°	49%	36%

ASME B30.9 - 2006

Weights of Material

Materials and Liquids – Pounds / cu. ft.			
Aluminum	165	Granite	96
Asbestos	153	Iron Casting	450
Asphalt	81	Lead	710
Brass	524	Limestone	95
Brick, Soft	100	Lumber, Fir	32
Brick, Medium	115	Lumber, Oak	62
Brick, Hard	130	Lumber, Rail Road Ties	50
Bronze	534	Marble	95
Coal	56	Oil, Motor	60
Concrete, Reinforced	150	Paper	58
Copper	556	Portland Cement, Loose	94
Crushed Rock	95	Portland Cement, Set	183
Diesel	52	River Sand	120
Dry Earth, Loose	75	Rubber	94
Dry Earth, Packed	95	Steel	490
Gasoline	45	Water, Fresh (8.42 lbs./gal.)	63
Glass	160	Zinc	437

Materials – Pounds / sq. ft.			
Steel Plate		Aluminum	
1/8"	5	1/8"	1.75
1/4"	10	1/4"	3.5
1/2"	20	1/2"	7
3/4"	31	3/4"	10.5
1"	41	1"	14

Formulas and Information

H = Height W = Width L = Length d = Diameter r = radius (1/2 dia.)
 $\pi = 3.14$

Area of a square or rectangle =	HW
Perimeter of Rectangle =	2(H+W)
Volume of cube =	HWL
Circumference of circle =	πd
Area of a circle =	πr^2
Volume of a Cylinder =	$\pi r^2 \times H$
Approximate area of a circle =	78.5% of the dia. ² (dia. x dia. x .785)

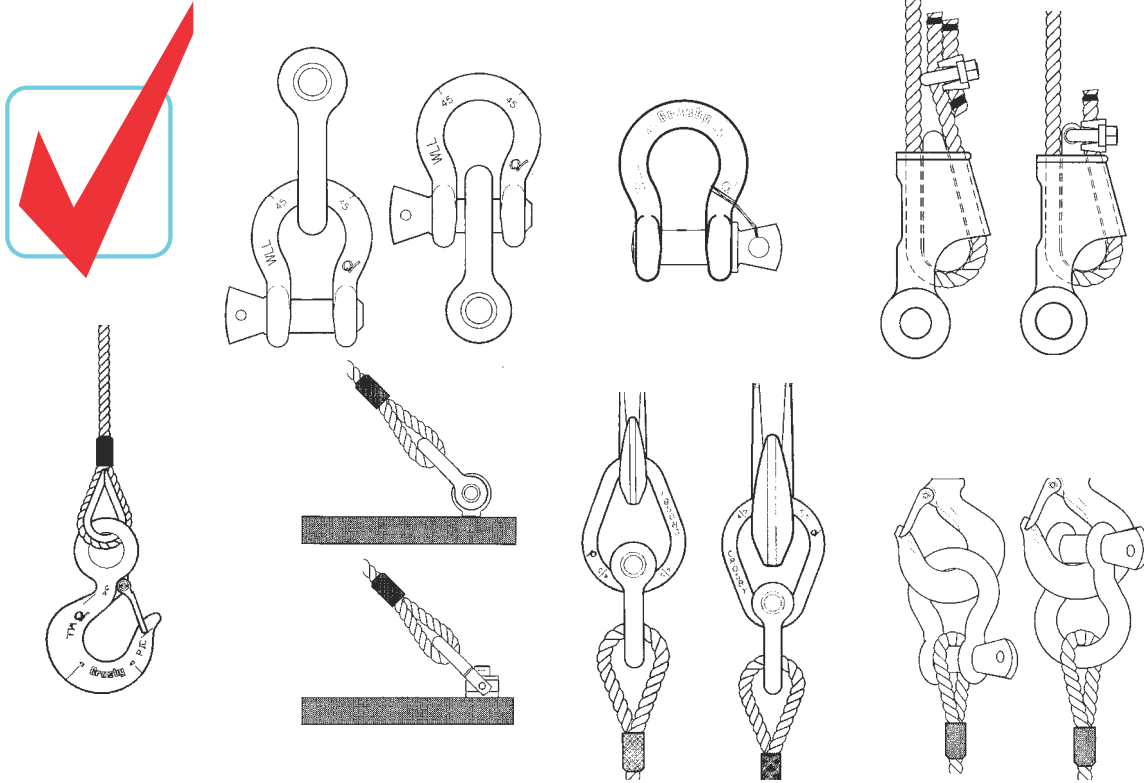
Fractional Equivalent (in.)	Decimal Equivalent (in.)	Metric Equivalent (mm)	Fractional Equivalent (in.)	Decimal Equivalent (in.)	Metric Equivalent (mm)
1/4"	.25	6.35	1-1/4"	1.250	31.75
3/8"	.375	9.525	1-3/8"	1.375	34.925
9/32"	.28125	7.143	1-1/2"	1.50	38.10
5/16"	.3125	7.932	1-3/4"	1.75	44.45
7/16"	.4375	11.112	2"	2.00	50.80
1/2"	.50	12.70	2-1/4"	2.25	57.15
9/16"	.5625	14.287	2-1/2"	2.50	63.5
5/8"	.625	15.875	2-3/4"	2.75	69.85
3/4"	.75	19.05	3"	3.00	76.20
7/8"	.875	22.225	3-1/2"	3.50	88.90
1"	1.00	25.40	4"	4.00	101.60
1-1/8"	1.125	28.575	4-1/2"	4.50	114.30

Weights	
1 lb. =	.45359 kg (kilogram)
1 kg. =	2.20462 lbs.
1 short ton (US) = 2,000 lbs.	= 907.185 kg
1 metric ton = 2,204.62 lbs.	= 1,000 kg
1 long ton = 2,240 lbs.	= 1,016.05 kg

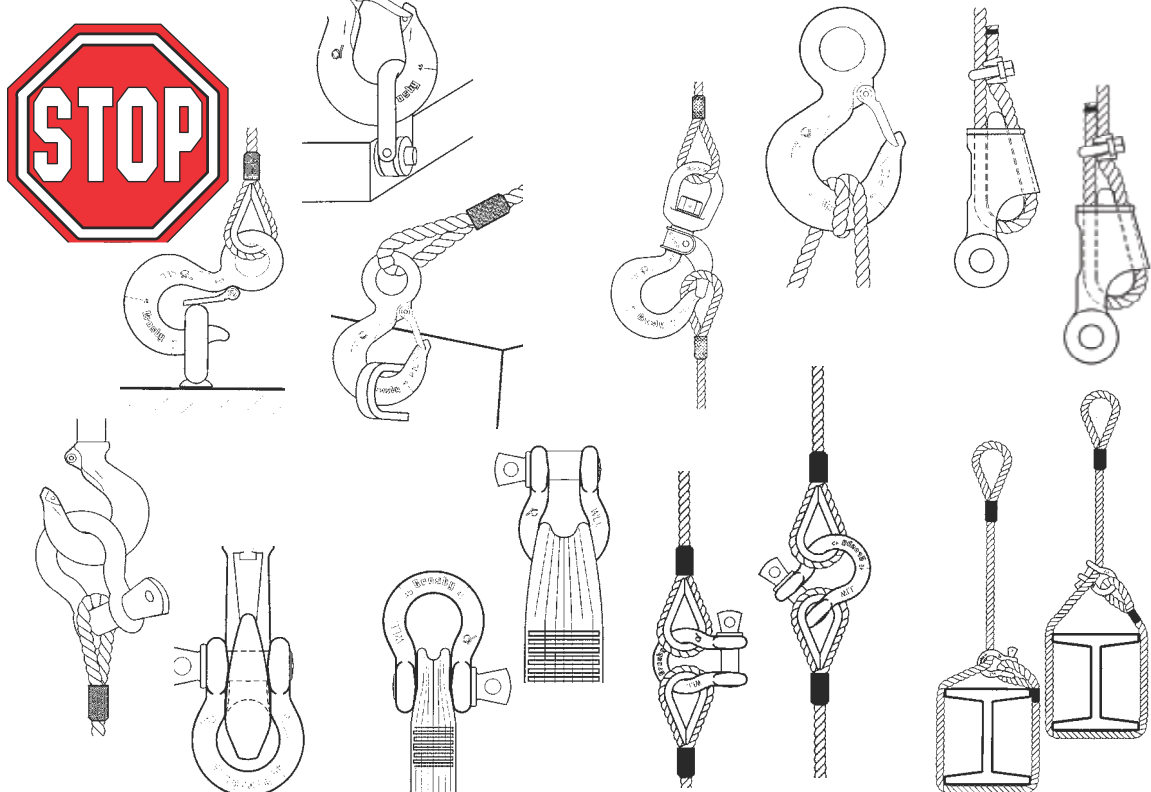
Breaking Force	
1 kN (kilo newton) = 101.937 kgf (kilogram/force)	
1 kN (kilo newton) = 224.820 pounds/force	
1 kip = 1,000 lbs.	

Mass/Unit Length			
1 inch	= 25.4 mm	1 mm	= .03937 inch
1 foot	= .3048 m (meter)	1 cm	= .3937 inch
1 yard	= .9144 m (meter)	1 m (meter)	= 3.28084 ft.
1 mile	= 1,609 m (meter)	1 m (meter)	= 39.3701 inch
1 rod	= 5.5 yards/15.5 ft.	1 shot	= 90 ft./15 fathoms
1 chain	= 22 yards/66 ft.		

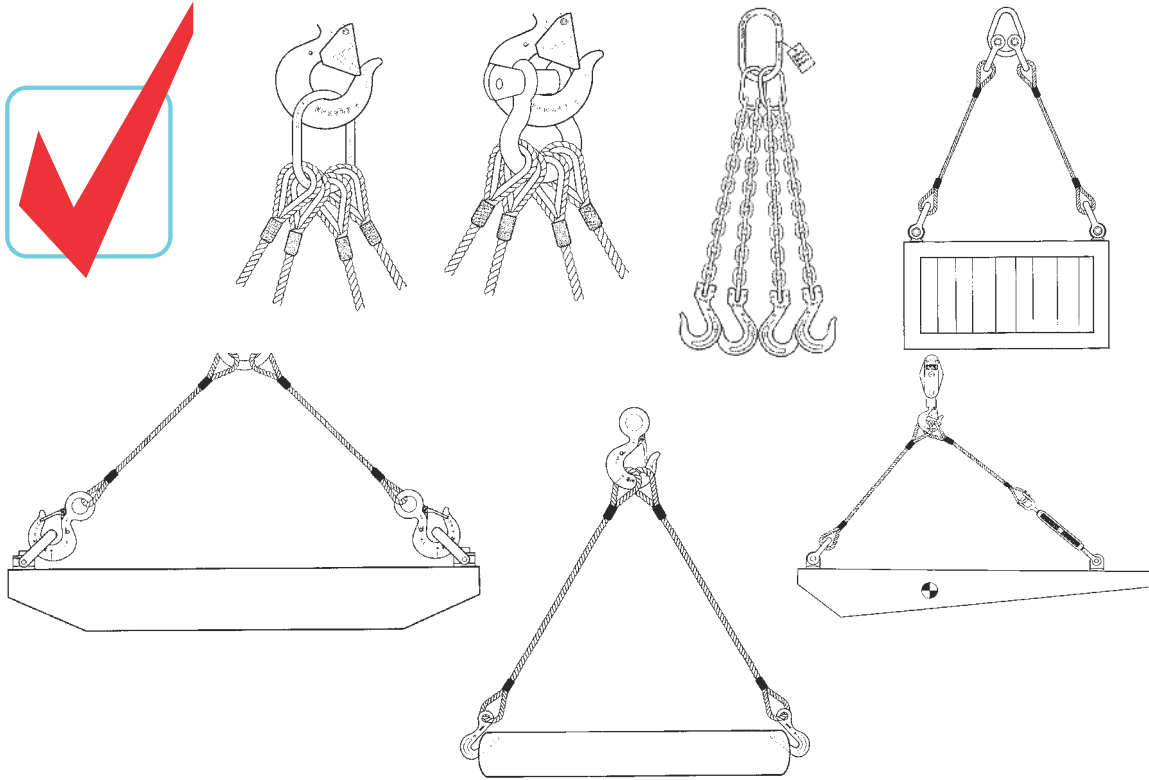
DISCUSS THE USE OF THE HARDWARE



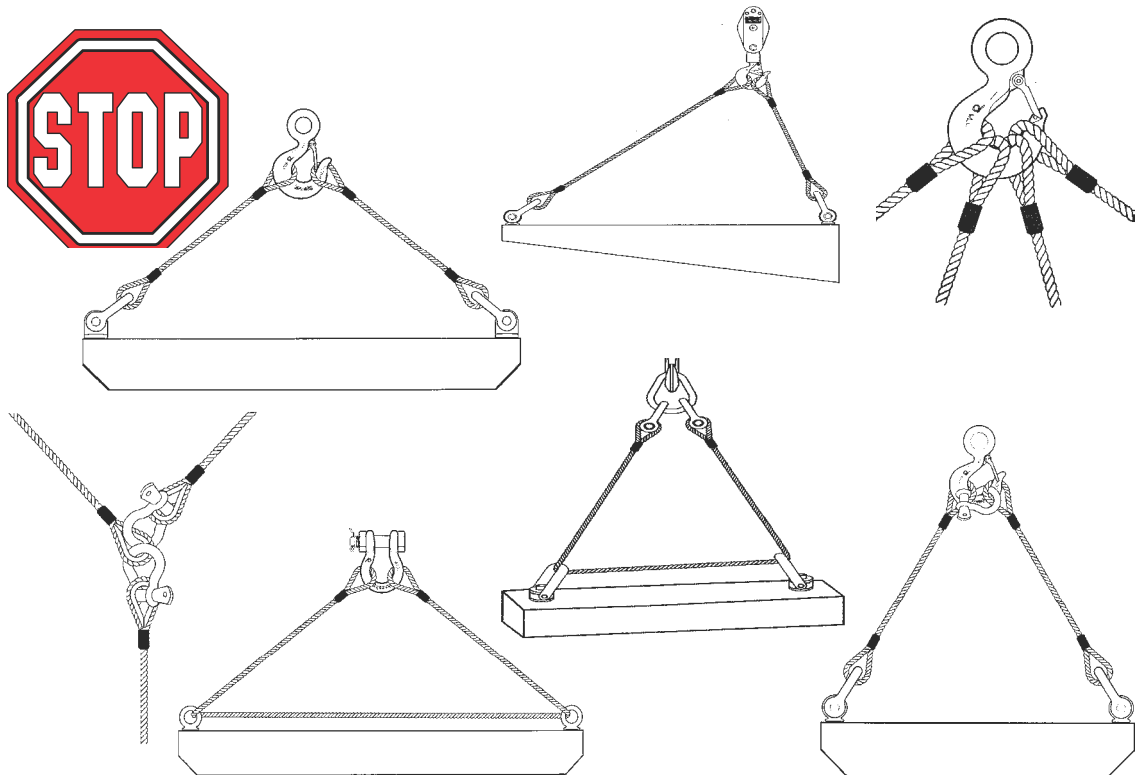
DISCUSS THE USE OF THE HARDWARE



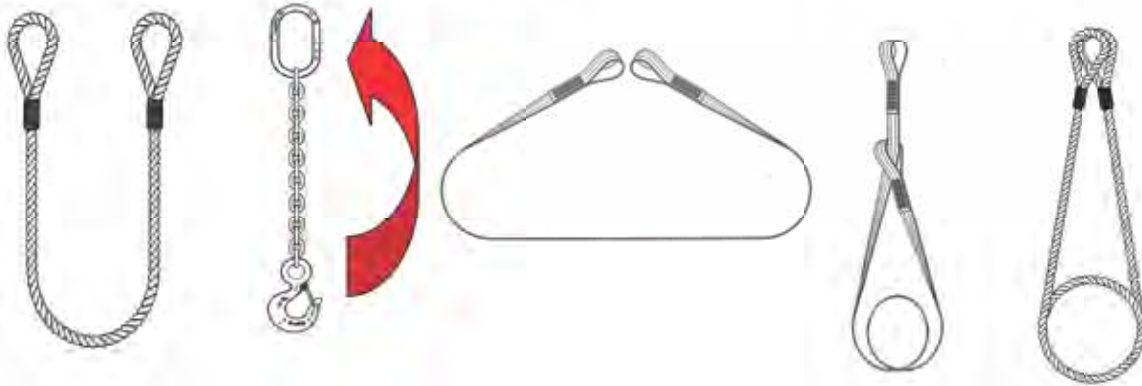
DISCUSS THE USE OF THE HARDWARE



DISCUSS THE USE OF THE HARDWARE



**NAME THE HITCH
DETERMINE CAPACITY COMPARED TO VERTICAL OR SINGLE LEG
DISCUSS APPLICATION**



**IF THE SLING IS A
1/2" WIRE ROPE SLING
EIP – FLEMISH EYE**

**IDENTIFY THE NAME
AND CAPACITY FOR
EACH HITCH SHOWN**



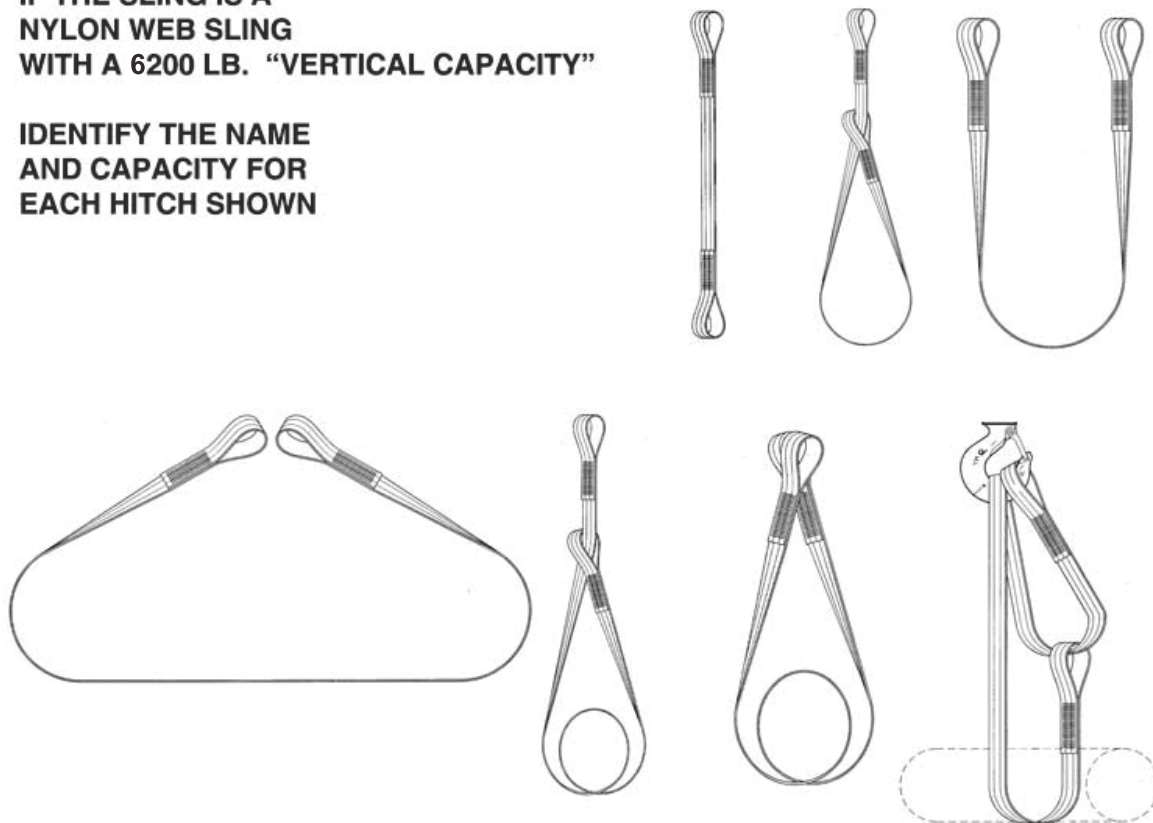
**IF THE SLING IS A
1/2" GRADE 10 CHAIN SLING**

**IDENTIFY THE NAME
AND CAPACITY FOR
EACH HITCH SHOWN**



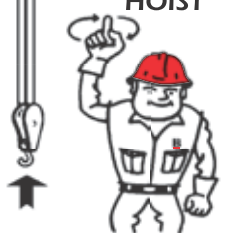
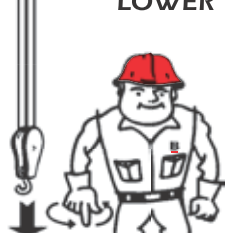

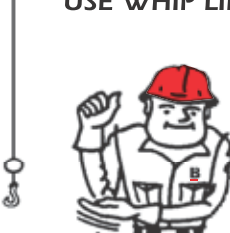
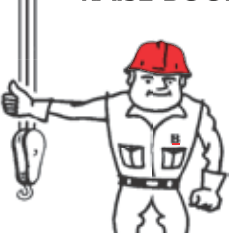


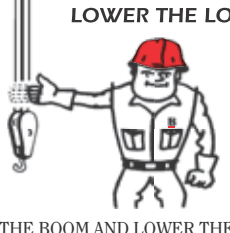
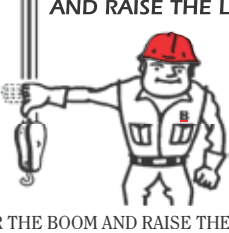

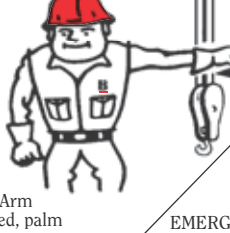
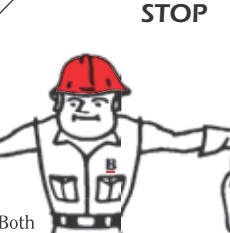
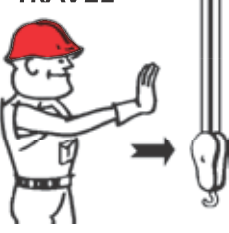



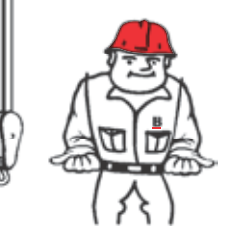
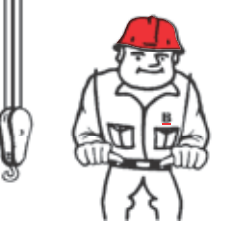


**IF THE SLING IS A
NYLON WEB SLING
WITH A 6200 LB. "VERTICAL CAPACITY"**

**IDENTIFY THE NAME
AND CAPACITY FOR
EACH HITCH SHOWN**





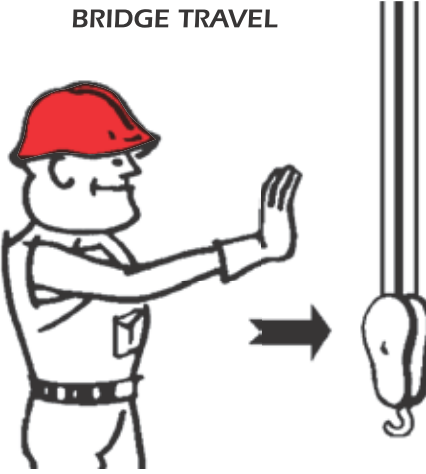


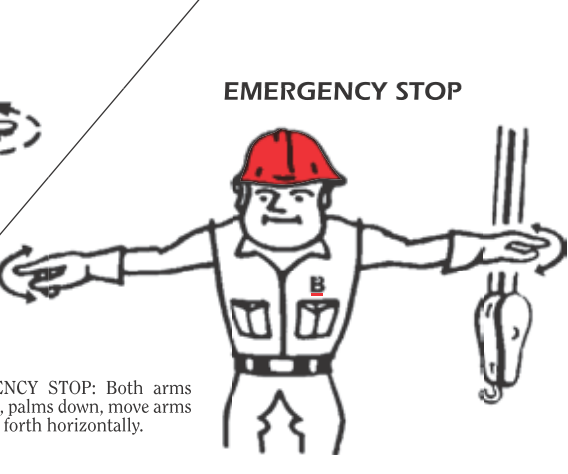
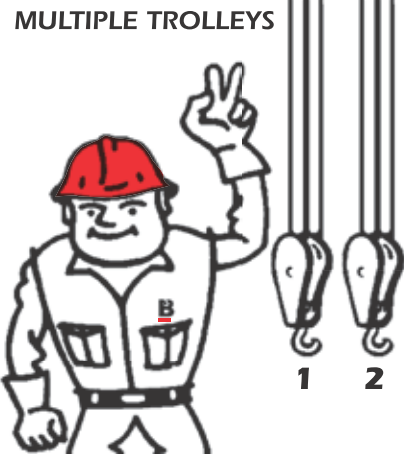
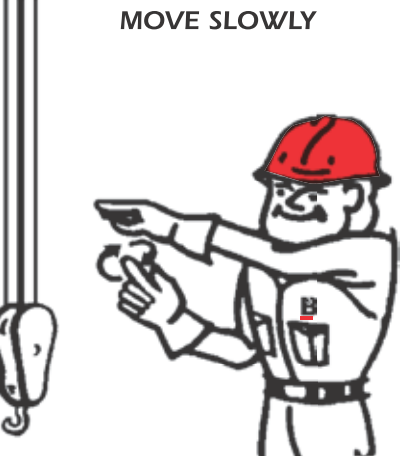
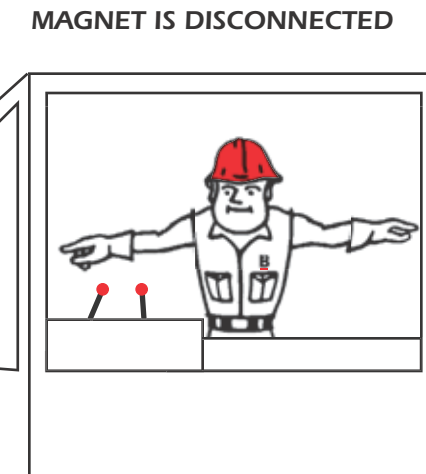
Mobile Crane Signals

Always Stand in Clear View of your Crane Operator

<p>HOIST</p>  <p>HOIST: With forearm vertical, forefinger pointing up, move hand in small horizontal circles.</p>	<p>LOWER</p>  <p>LOWER: (Auxiliary Hoist) With arm extended downward, forefinger pointing down, move hand in small horizontal circles</p>	<p>USE MAIN HOIST</p>  <p>USE MAIN HOIST: Tap fist on head, then use regular signals.</p>	<p>USE WHIP LINE</p>  <p>USE WHIP LINE: (Auxiliary Hoist) Tap elbow with one hand, then use regular signals</p>
<p>RAISE BOOM</p>  <p>RAISE BOOM: Arm extended, fingers closed, thumb pointing upward.</p>	<p>LOWER BOOM</p>  <p>LOWER BOOM: Arm extended, fingers closed, thumb pointing downward.</p>	<p>MOVE SLOWLY</p>  <p>MOVE SLOWLY: Use one hand to give any motion signal and place other hand motion less in front of hand giving the motion signal. (Hoist slowly shown as example)</p>	<p>RAISE THE BOOM AND LOWER THE LOAD</p>  <p>RAISE THE BOOM AND LOWER THE LOAD: With arm extended, thumb pointing up, flex fingers in and out as long as load movement is desired.</p>
<p>LOWER THE BOOM AND RAISE THE LOAD</p>  <p>LOWER THE BOOM AND RAISE THE LOAD: With arm extended, thumb pointing down, flex fingers in and out as long as movement is desired.</p>	<p>SWING</p>  <p>SWING: Arm extended, point with finger in direction of swing of boom.</p>	<p>STOP</p>  <p>STOP: Arm extended, palm down, move arm back and forth horizontally.</p>	<p>EMERGENCY STOP</p>  <p>EMERGENCY STOP: Both arms extended, palms down, move arms back and forth horizontally.</p>
<p>TRAVEL</p>  <p>TRAVEL: Arm extended forward, hand open and slightly raised, making pushing motion in direction of travel.</p>	<p>DOG EVERYTHING</p>  <p>DOG EVERYTHING: Clasp hands in front of body.</p>	<p>TRAVEL (BOTH TRACKS)</p>  <p>TRAVEL (BOTH TRACKS): Use both fists in front of body, making a circular motion about each other, indicating direction of travel, forward or backward. (For land cranes only.)</p>	<p>TRAVEL (ONE TRACK)</p>  <p>TRAVEL (ONE TRACK): Lock the track on side indicated by raised fist. Travel opposite track in direction indicated by circular motion of other fist, rotated vertically in front of body. (For land cranes only.)</p>
<p>EXTEND BOOM</p>  <p>EXTEND BOOM (TELESCOPING BOOMS): Both fists in front of body with thumbs pointing outward.</p>	<p>RETRACT BOOM</p>  <p>RETRACT BOOM (TELESCOPING BOOMS): Both fists in front of body with thumbs pointing toward each other.</p>	<p>EXTEND BOOM</p>  <p>EXTEND BOOM (TELESCOPING BOOMS): One hand signal. One fist in front of chest with thumb tapping chest.</p>	<p>RETRACT BOOM</p>  <p>RETRACT BOOM (TELESCOPING BOOMS): One hand signal. One fist in front of chest, thumb pointing outward and heel of fist tapping chest.</p>

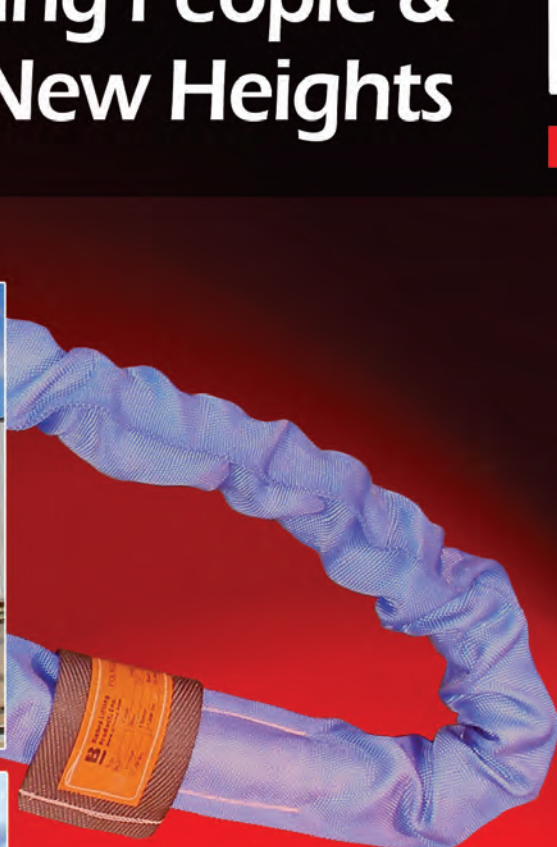
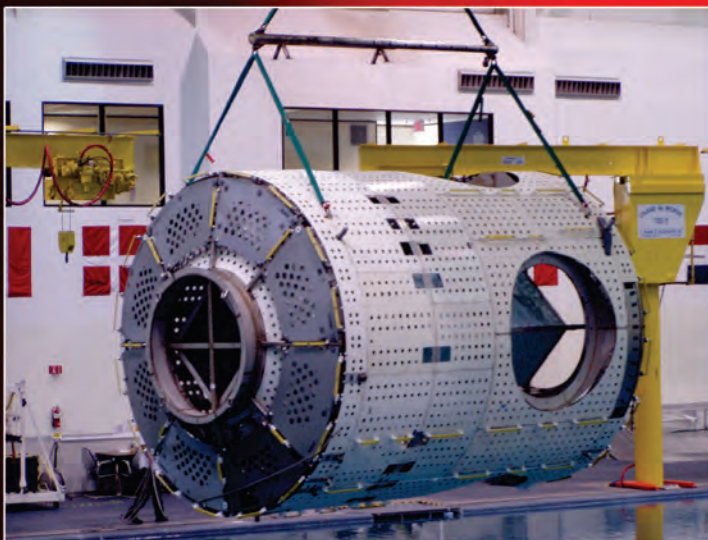
Reprinted from ASME B30.5-2004, by permission of the American Society of Mechanical Engineers

Overhead and Gantry Crane Signals
Always Stand in Clear View of your Crane Operator

<p style="text-align: center;">HOIST</p>  <p>HOIST: With forearm vertical, forefinger pointing up, move hand in small horizontal circle.</p>	<p style="text-align: center;">LOWER</p>  <p>LOWER: With arm extended downward, forefinger pointing down, move hand in small horizontal circle.</p>	<p style="text-align: center;">BRIDGE TRAVEL</p>  <p>BRIDGE TRAVEL: Arm extended forward, hand open and slightly raised, make pushing motion in direction of travel.</p>
<p style="text-align: center;">TROLLEY TRAVEL</p>  <p>TROLLEY TRAVEL: Palm up, fingers closed, thumb pointing in the direction of motion, jerk hand horizontally.</p>	<p style="text-align: center;">STOP</p>  <p>STOP: Arm extended, palm down, move arm back and forth horizontally.</p> <p style="text-align: center;">EMERGENCY STOP</p>  <p>EMERGENCY STOP: Both arms extended, palms down, move arms back and forth horizontally.</p>	
<p style="text-align: center;">MULTIPLE TROLLEYS</p>  <p>MULTIPLE TROLLEYS: Hold one finger for block marked "1", and two fingers for block marked "2." Regular signals follow.</p>	<p style="text-align: center;">MOVE SLOWLY</p>  <p>MOVE SLOWLY: Use one hand to give any motion signal and place other hand motionless in front of hand giving the motion signal. (Hoist slowly shown as example.)</p>	<p style="text-align: center;">MAGNET IS DISCONNECTED</p>  <p>MAGNET IS DISCONNECTED: Crane operator spreads both hands apart – palms down.</p>

Reprinted from ASME B30.2-2005, by permission of the American Society of Mechanical Engineers

Lifting People & Materials to New Heights





Bishop Lifting Products, Inc.

125 McCarty Dr.
Houston, TX 77029
Tel: (713) 674-2266
Fax: (713) 672-9229
Toll Free: (800) 972-1041

2160 Wellspring
Beaumont, TX 77705
Tel: (409) 729-9187
Fax: (409) 724-2659

8416 W. Highway 90
New Iberia, LA 70560
Tel: (337) 369-3903
Fax: (337) 369-3904
Toll Free: (888) 369-3903

1821 Yellowstone Rd.
Rock Springs, WY 82901
Tel: (307) 382-6622
Fax: (307) 382-2401
Toll Free: (877) 511-6622

